

# **Agilent B1505A Power Device Analyzer/ Curve Tracer**

## **Quick Start Guide**



**Agilent Technologies**

# Notices

© Agilent Technologies, Inc. 2009

No part of this manual may be reproduced in any form or by any means (including electronic storage and retrieval or translation into a foreign language) without prior agreement and written consent from Agilent Technologies, Inc. as governed by United States and international copyright laws.

## Manual Part Number

B1505-90030

## Edition

Edition 1, October 2009

Agilent Technologies  
5301 Stevens Creek Blvd  
Santa Clara, CA 95051 USA

## Warranty

**The material contained in this document is provided "as is," and is subject to being changed, without notice, in future editions. Further, to the maximum extent permitted by applicable law, Agilent disclaims all warranties, either express or implied, with regard to this manual and any information contained herein, including but not limited to the implied warranties of merchantability and fitness for a particular purpose. Agilent shall not be liable for errors or for incidental or consequential damages in connection with the furnishing, use, or performance of this document or of any information contained herein. Should Agilent and the user have a separate written agreement with warranty terms covering the material in this document that conflict with these terms, the warranty terms in the separate agreement shall control.**

## Technology Licenses

The hardware and/or software described in this document are furnished under a license and may be used or copied only in accordance with the terms of such license.

## Restricted Rights Legend

If software is for use in the performance of a U.S. Government prime contract or subcontract, Software is delivered and licensed as "Commercial computer software" as defined in DFAR 252.227-7014 (June 1995), or as a "commercial item" as defined in FAR 2.101(a) or as "Restricted computer software" as defined in FAR 52.227-19 (June 1987) or any equivalent

agency regulation or contract clause. Use, duplication or disclosure of Software is subject to Agilent Technologies' standard commercial license terms, and non-DOD Departments and Agencies of the U.S. Government will receive no greater than Restricted Rights as defined in FAR 52.227-19(c)(1-2) (June 1987). U.S. Government users will receive no greater than Limited Rights as defined in FAR 52.227-14 (June 1987) or DFAR 252.227-7015 (b)(2) (November 1995), as applicable in any technical data.



## Table of Contents

Take thirty minutes to walk through a demonstration of our next-generation power device analyzer / curve tracer— the Agilent B1505A. It has many new functions that are not present in traditional curve tracers. The demonstration is based on basic measurements of the power devices (MOSFET, BJT).

Topic	Page
<b>Lab 0</b> Before Starting the Demo - Information of the instruments and devices for demo. - Setup for the demo.	3
<b>Lab 1</b> Tracer Test Mode - Easier operation than traditional curve tracers. - Using knob to measure $I_d$ - $V_{ds}$ and $BV_{dss}$ .	12
<b>Lab 2</b> Application Test Mode - Easy setups for $I_d$ - $V_{ds}$ , $I_d(\text{off})$ - $V_{ds}$ , $I_d$ - $V_{gs}$ and $C_{gd}$ measurements.	20
<b>Lab 3</b> Classic Test Mode 1 - High Voltage CV measurement.	28
<b>Lab 4</b> Classic Test Mode 2 - Calculate $R_e$ from $I_b$ - $V_{ce}$ measurement results.	32
<b>Lab 5</b> Convert the Tracer Test Mode setups to the Classic Test Mode setups - Seamless setup conversion.	38
<b>Lab 6</b> Data analyze on your PC with the Desktop EasyEXPERT - Easy data transfer and analyze.	42

## Before using B1505A

### WARNING

**There are potentially hazardous voltages (3000 V for HVSMU, and 200 V for HPSMU) present at the Force, Sense, and Guard terminals of Agilent B1505A. To prevent electrical shock, the following safety precautions must be observed during the use of B1505A.**

- Use a three-conductor AC power cable to connect the cabinet (if used) and B1505A to an electrical ground (safety ground).
- You must connect an interlock cable between B1505A and the test fixture.
- Confirm periodically that the interlock function is functional.
- **Do not modify the interlock circuit.**
- Do not use extension cables for connecting the DUT the outside of the test fixture.
- Before touching the connections on the Force, Guard, and Sense terminals, turn the B1505A off and discharge any capacitors. If you do not wish to turn the B1505A off, complete all of the following items, regardless of the B1505A settings.
  - Press the Stop key to turn the module output off.
  - Confirm that the High Voltage indicator is not lit.
  - Open the shielding box access door.
  - Discharge any capacitors connected to an SMU.

# Instruments and Accessories used in this DEMO

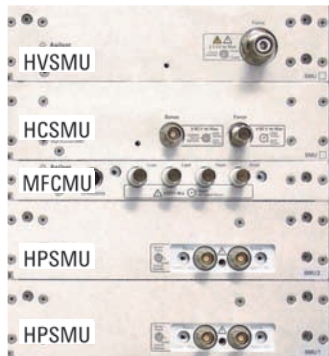

*B1505A Modules*



*Agilent N1259A*

- Agilent B1505A Power Device Analyzer / Curve Tracer
  - 1 X HVSMU (B1513A) High Voltage SMU
  - 1 X HCSMU (B1512A) High Current SMU
  - 2 X HPSMU (B1510A) High Power SMU
  - 1 X MFCMU (B1520A) Multi-Frequency CMU
  
- Agilent N1259A High Power Test Fixture
  - Opt 020 High Voltage Biass Tee
  - Opt 300 Module Selector
  - Opt 010 Inline package socket module (3 pin)
  - Opt 022 100 kOhm R-Box
  - Opt 033 1 kOhm R-Box
  - (10 X Test leads, 2 X SHV cables and SHV-Banana adapt-ers are including in the N1259A)
  
- Cables
  - 1 X 16493S HCSMU Cable
  - 1 X 16493T HV Triax Cable
  - 4 X 16494A Triax Cable
  - 1 X 16493L GNDU Cable
  - 1 X N1300A CMU Cable
  - 1 X 16493J Interlock Cable
  - 1 X 16493G Digital I/O Cable



*16493T HV Triax*



*16494A Triax Cable*



*N1300A CMU Cable*



*16493T HCSMU Cable*



*16493J Interlock Cable*



*16493G Digital I/O Cable*

## Demo Devices

The following devices are used in this document;

### Power MOS FET

2SK3745LS



- $BV_{dss}$ : >1500 V (ID=1 mA, Vgs=0 V)
- $I_{dss}$ : <100  $\mu$ A (Vds=1200 V, Vgs=0 V)
- $I_{gss}$ : <10  $\mu$ A (Vgs=10 V, Vds=0 V)
- $V_{gs(off)}$ : 2.5-3.5 V (Vds=10 V, Id=1 mA)
- $|y_{fs}|$ : >0.7 S, typ. 1.4 S (Vds=20 V, Id=1 A)
- $R_{ds(on)}$ : <12  $\Omega$  typ. 10  $\Omega$  (Id=1A, Vgs=10V)
- $C_{iss}$ : typ. 380 pF (Vds=30 V, f=1 MHz)
- $C_{oss}$ : typ. 70 pF (Vds=30 V, f=1 MHz)
- $C_{rss}$ : typ. 40 pF (Vds=30 V, f=1 MHz)

### Power Bipolar Junction Transistor

MJL4281AG

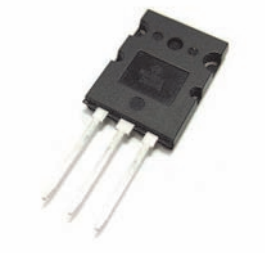

- $V_{ce(sus)}$ : 350 V (Ic=50 mA, Ib=0 A)
- $I_{ceo}$ : 100  $\mu$ A (Vce=200 V, Ib=0 A)
- $I_{cbo}$ : 50  $\mu$ A (Vcb=350 V, Ie=0 A)
- $I_{ebo}$ : 5  $\mu$ A (Veb=5 V, Ic=0 A)
- $h_{FE}$ : 80 -250 (Ic=0.1-5 A, Vce=5 V)
- $V_{ce(sat)}$ : <1 V (Ic=8 A, Ib=0.8 A)
- $V_{be(sat)}$ : <1.4 V (Ic=8 A, Ib=0.8 A)
- $V_{be(on)}$ : <1.5 V (Ic=8 A, Vce=5 V)
- $C_{ob}$ : typ. 600 pF (Vcb=10 V, Ie=0, f=1 MHz)



# Agilent B1505A Power Device Analyzer / Curve Tracer

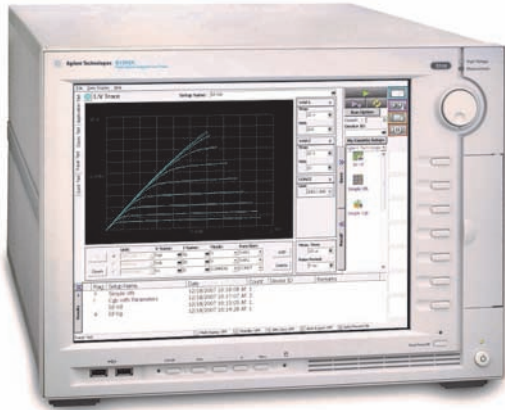

*Agilent B1505A Power Device/ Curve Tracer*

Agilent B1505A Power Device Analyzer / Curve Tracer is designed for measuring present power devices. B1505A uses the EasyEXPERT software, a specially-designed Microsoft Windows application program.

B1505A has 10 module slots, which supports the following modules.

- B1510A High Power SMU
- B1512A High Current SMU
- B1513A High Voltage SMU
- B1520A Multi Frequency CMU

HPSMU Output and Measurement Ranges

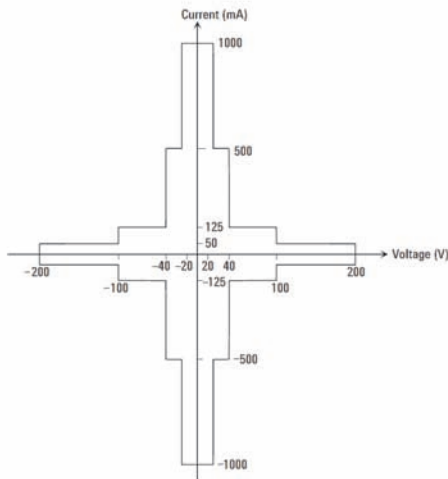

Output and measurement range of each module are described in the figures on this page.

For more information, refer to the B1505A User's Guide.

HCSMU Output and Measurement Ranges

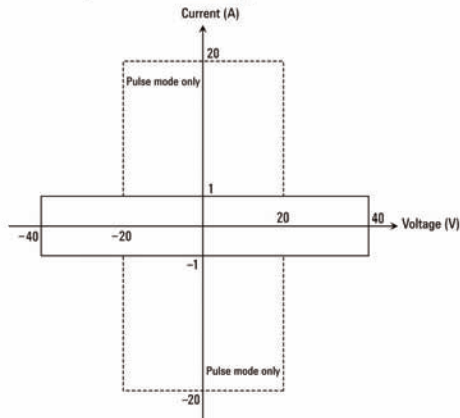

HVSMU Output and Measurement Ranges

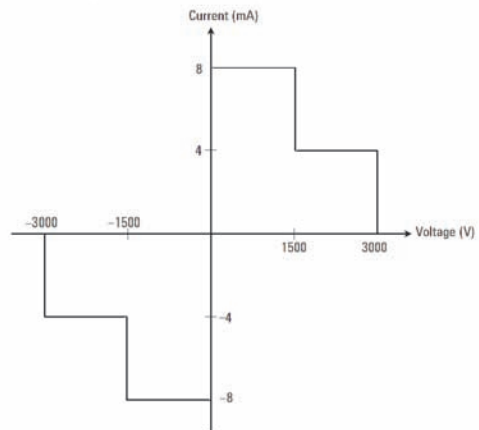



# Agilent N1259A Power Device Test Fixture



Agilent N1259A Test Fixture

Agilent N1259A Power Device Test Fixture is used to perform the present power packaged device measurement.

N1259A is capable of handling 3000 V maximum voltage and 20 A maximum current. It uses internal guarded wiring for improving low current measurement capability.

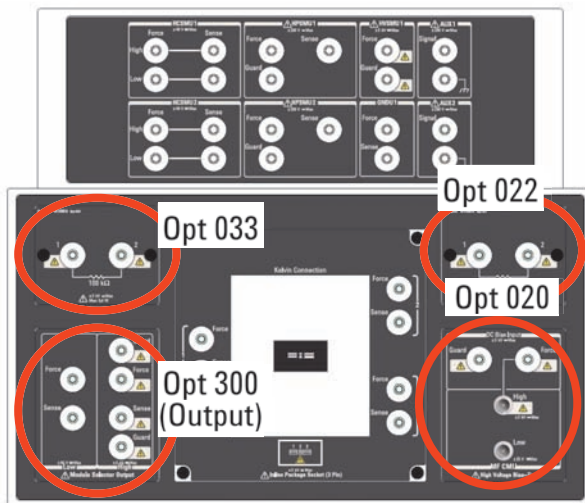

N1259A Opt 020, 022 and 300

For this demo, we will use N1259A with options 022, 033, 020 and 300.

Options 022, 033 are resistors, which is used for suppressing device self-oscillation of the DUT.

Option 020 is a High Voltage Bias-Tee, for high voltage C-V measurements. HV C-V measurement up to 3000 VDC (frequency range of 10 kHz to 1 MHz) can be achieved by using this MFCMU, HVSMU and the bias-Tee.

Option 300 is a module selector, which is used to switch the measurement resource (HPSMU, HVSMU and HCSMU) automatically connected to the device under test (DUT). The left figure shows a block diagram of the module selector. It also provides a GNDU connection, with a return path for the HCSMU.

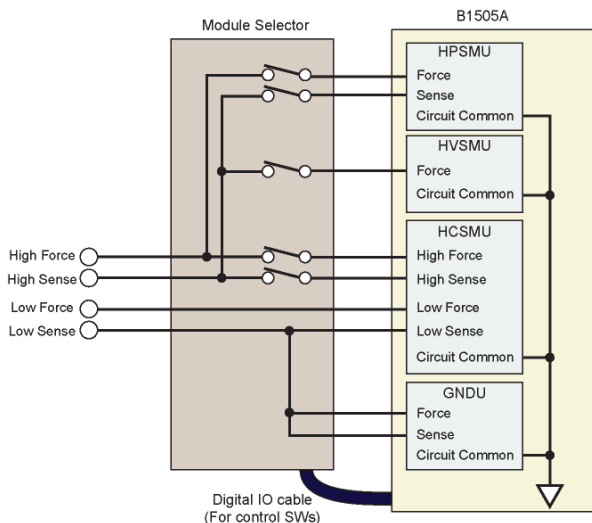

Block Diagram of the Module Selector

**IMPORTANT: The Force output of the HVSMU is connected to High Sense output of the Module selector (NOT to High Force).**

# Connections for the Demo

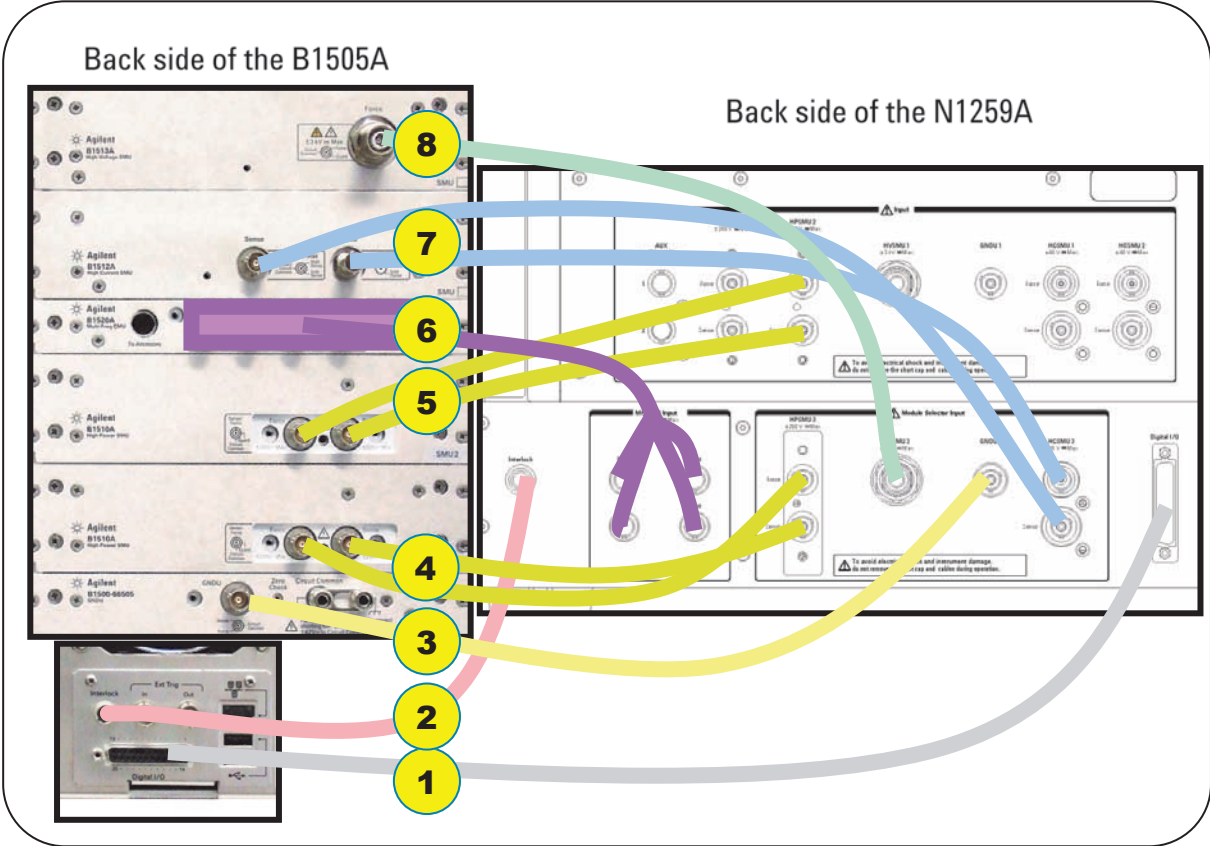

Total connection setup for the demo.

Before starting the demo, connect the cables between the B1505A and the N1259A. These connections will be used for all demos, and will not need to be changed.

Procedure:

1. Using a 16493G Digital I/O Cable, connect the Digital I/O connector on the B1505A to the Digital I/O connector on the N1259A test fixture.



- Using a 16493J Interlock Cable, connect the Interlock on the B1505A and the Interlock on the N1259A.



- Using a 16493L GNDU Cable, connect the GNDU on the B1505A to the GNDU2 (Module selector Input) on the N1259A.



- Using two 16494A Triax Cables, connect the Force and Sense connectors on the lower B1510A HPSMU (SMU1) to the respective connectors on the HPSMU3 (Module selector input) of the N1259A.



- Using two 16494A Triax Cables, connect the upper B1510A HPSMU (SMU2) to the HPSMU2 on the N1259A.



- Using a N1300A CMU Cable, connect the B1520A CMU to the MF CMU Input (Hcur, Hpot, Lcur, Lpot) on the N1259A.

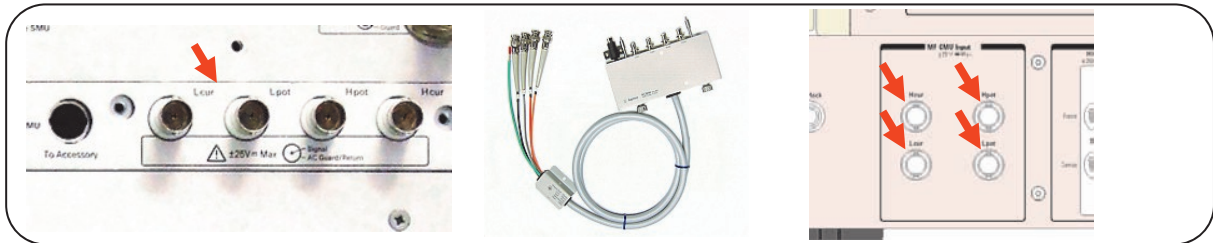

- Using a 16493S HCSMU Cable, connect the Force and Sense connectors on the B1512A HCSMU to the HCSMU3 Input on the N1259A.

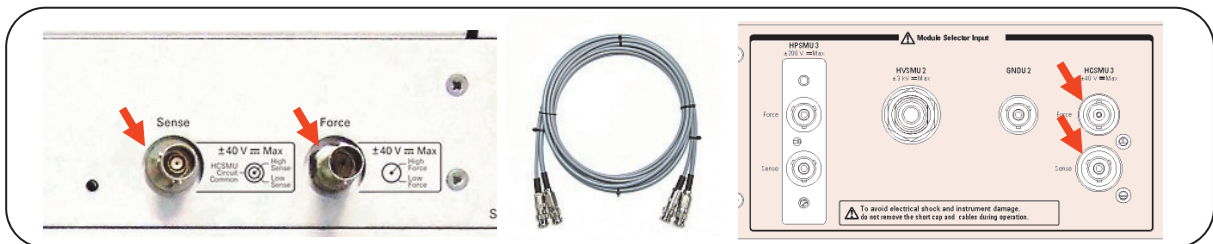

- Using a 16493T HV Triax Cable, connect the Force connector on the B1513A HVSMU to the HVSMU2 (Module selector input) of the N1259A.





# Start B1505A

After connecting the cables, power on the B1505A. And then start the EasyEXPERT software.



If you have any problems, please refer to the manuals (B1505A User's Guide, EasyEXPERT Software User's Guide, EasyEXPERT Application Library Reference, etc.) for more details on the EasyEXPERT software.

Before starting the demo, check the settings for the module selector. You can view and change the configuration of the module selector as follows.

## IMPORTANT

1. Click the configuration button  on the right side of the screen.
2. Select the Module selector tab.

The correct settings are shown below.

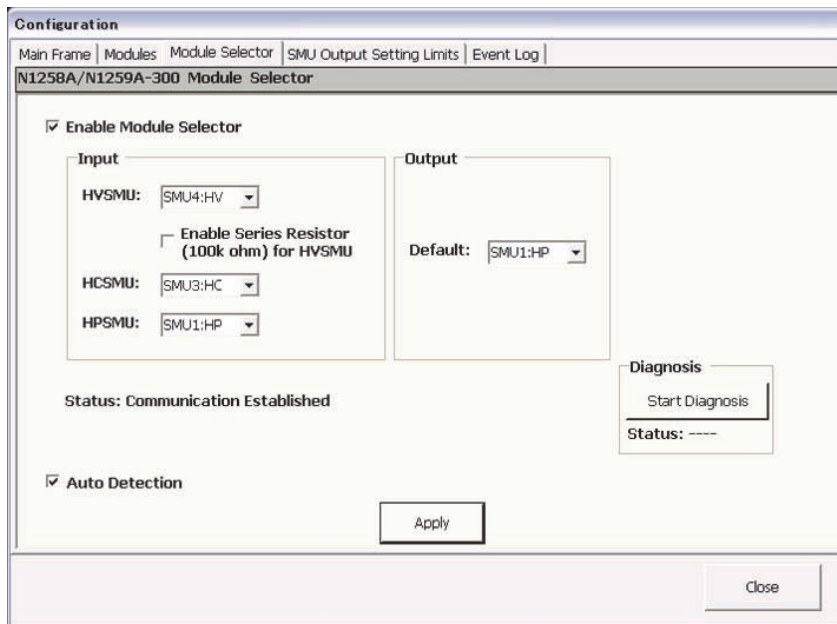

## Lab 1 Tracer Test Mode

- Easier operation than traditional curve tracers.
- Using knob to measure  $I_d$ - $V_{ds}$  and  $BV_{dss}$ .

**Objective** B1505A has a Tracer Test Mode, designed for a simpler, more intuitive, and easier operation than on the traditional curve tracers. It is also much easier to use and it offers more functions than traditional curve tracers. This section explains the usage and functions of the Tracer Test Mode.

- Point**
- Usability of the Trace Test mode
  - Sample setup
  - DC mode / Pulse Mode
  - Reference Trace
  - Trace Recorder
  - High Voltage Measurement
  - Module Selector

**Device** MOS FET (2SK3745LS)

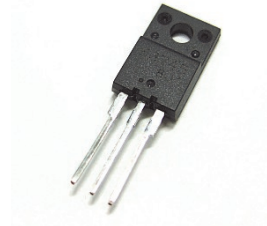

**Setup** Open the N1259A test fixture cover, and connect the test leads as follows. Refer to the drawing on the next page. The numbers on the drawing correspond to the procedure steps.

1. Insert the device (2SK3745LS) into the socket on the N1259A.
2. Connect the HPSMU2 Force to the terminal 1 on the 1 k $\Omega$  resistor.
3. Connect the terminal 2 on the 1 k $\Omega$  resistor to the terminal 1 Force (Gate) on the Inline Package Socket .



*Test Lead for the N1259A Test Fixture*

4. Connect the High Force of the Module Selector Output to the terminal 2 Force (Drain) on the Inline Package Socket .
5. Connect the High Sense of the Module Selector Output to the terminal 2 Sense (Drain) on the Inline Package Socket .
6. Connect the Low Force of the Module Selector Output to the terminal 3 Force (Source) on the Inline Package Socket .
7. Connect the Low Sense of the Module Selector Output to the terminal 3 Sense (Source) on the Inline Package Socket .

Close the N1259A fixture cover.

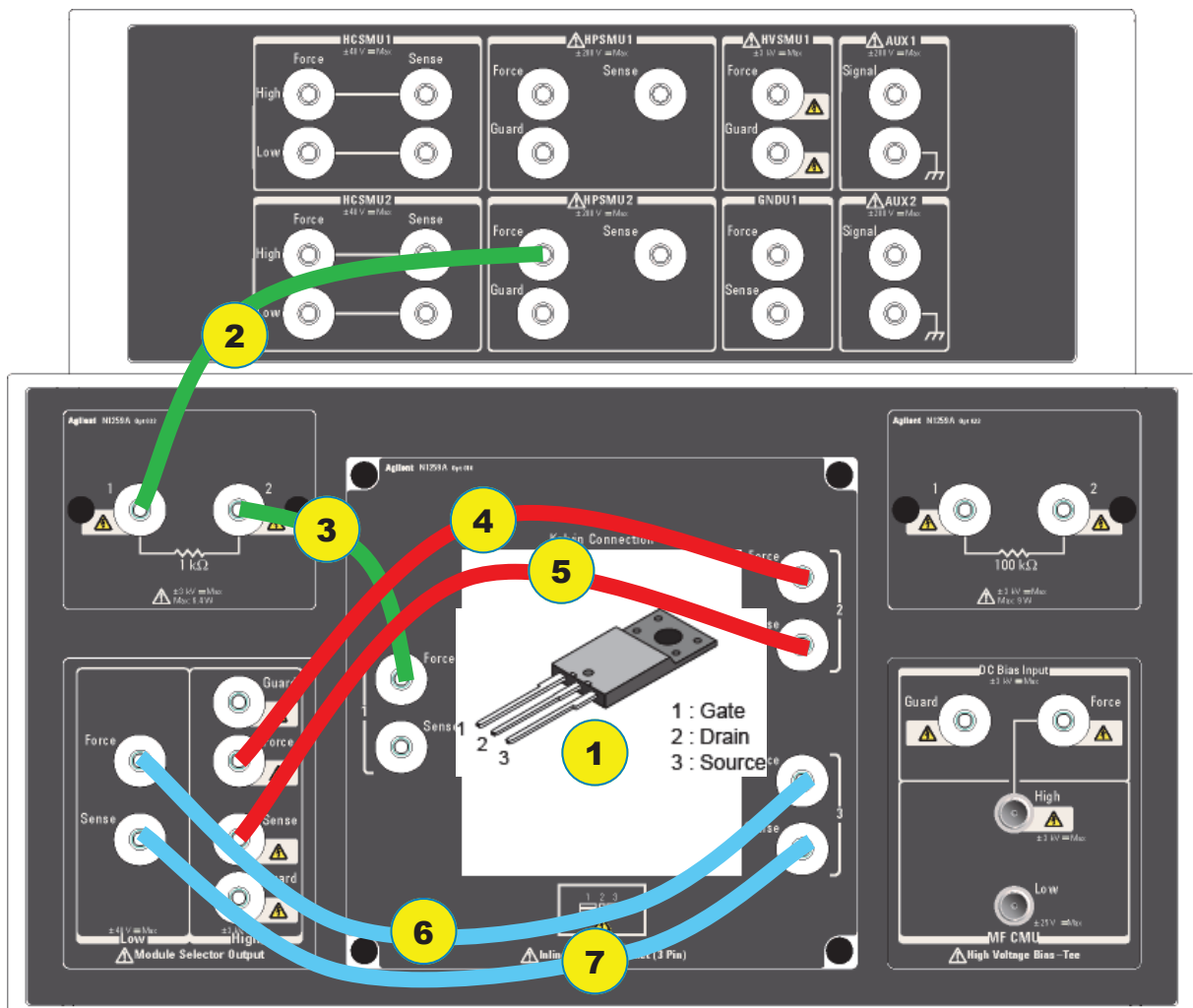



## Procedure Id-Vds Measurement

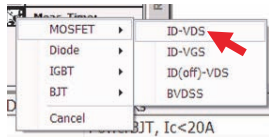

1. Click the (wrench and screw driver) icon  on bottom right of the window.

2. Select the sample setup for the MOSFET — ID-VDS.

3. Change the Mode of the SMU3:HC (VAR1) from VPULSE to V.

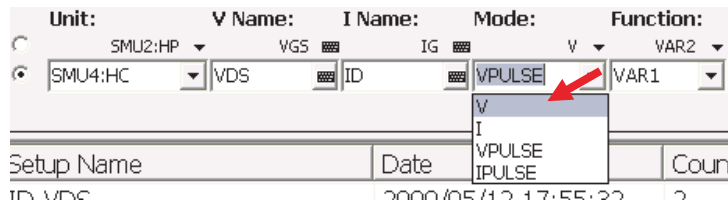

4. Change the VAR1 (ID) compliance to 1 A.

5. Change the VAR2 START voltage (VG) to 3.5 V.

6. Change the VAR2 STOP voltage (VG) to 5 V.

7. Confirm that the settings are as shown in the following picture.

8. Click the REPEAT button. 

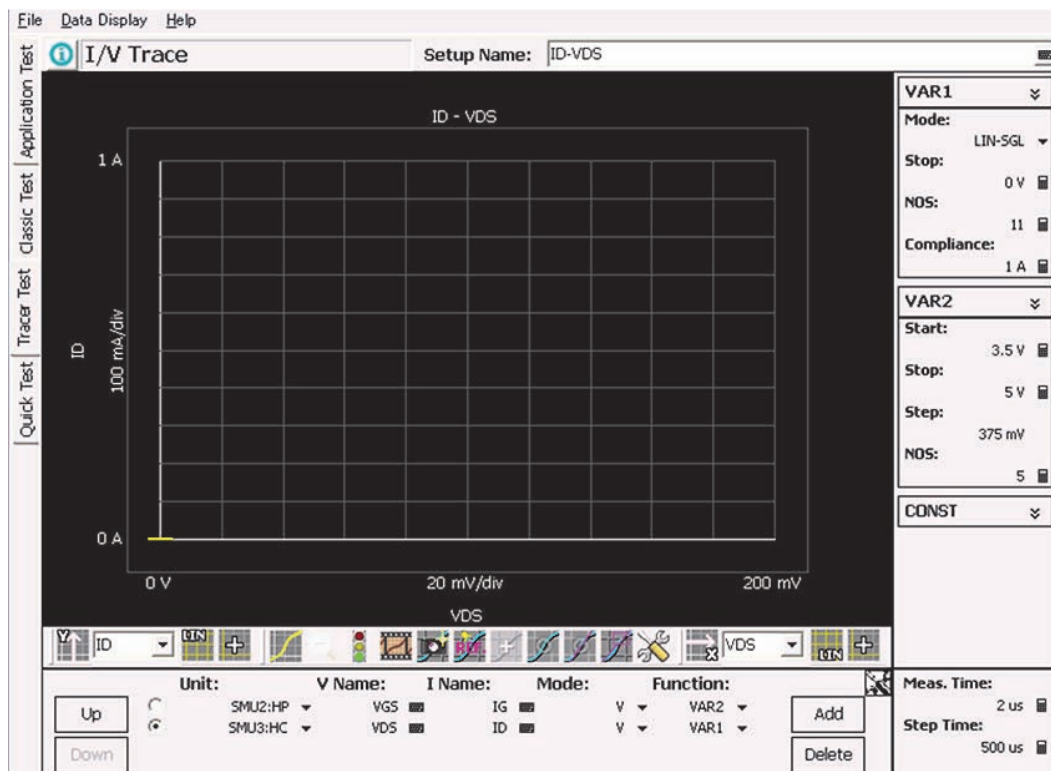
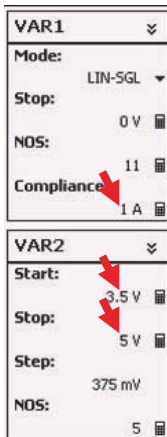

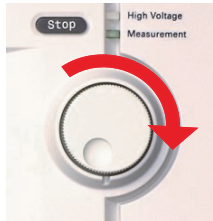
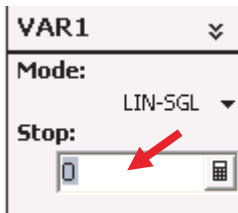

9. Click (Select) the VAR1 (VD) stop voltage.

10. Rotate the rotary knob on the front panel of the B1505A in the clockwise direction.

11. The stop voltage increases, and its graph is shown on the screen.

12. Set the stop voltage to 18 V.

13. Click the Capture button . You can capture the (reference) traces using this button. The captured traces are shown with blue lines.

14. The graph will drift due to the *self heating effect*.

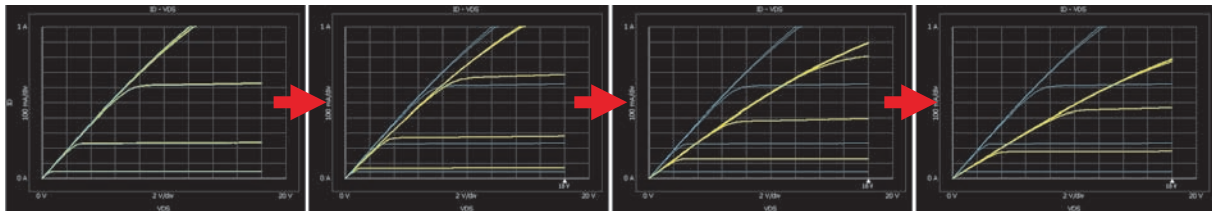
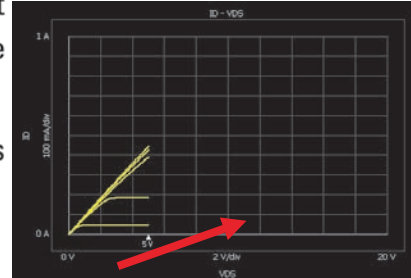

Time	Trace
2009/05/20 17:49:35	ID - VDS
2009/05/20 17:49:27	ID - VDS
2009/05/20 17:49:25	ID - VDS
2009/05/20 17:49:24	ID - VDS
2009/05/20 17:49:15	ID - VDS
2009/05/20 17:49:11	ID - VDS

15. You can save multiple traces by clicking the Capture button. 

16. The reference traces window (shown left) pops up when the Reference trace button  is clicked. You can enable / disable the traces for the graph display.

17. Click the STOP button  to stop the stimulus and measurement.

18. Click the VAR1 title bar  to see the details of the settings (Full mode).



19. Set the Power compliance to 3W. (Select Pwr Comp. then input 3.)

20. Wait for the DUT to cool.

21. Start the measurement again. (Click the repeat button .)

22. You will now see the graph on the next page, which is limited to 3W, with a smaller drift.

23. Click the STOP button  to stop the stimulus and measurement.

24. Wait for the DUT to cool.

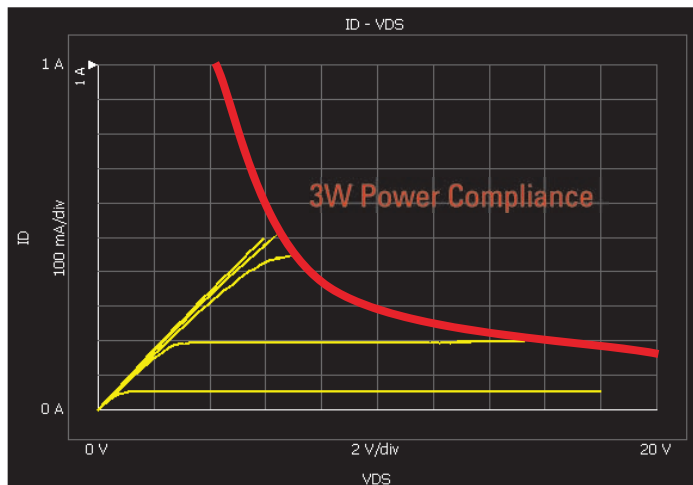

Now we measured the DUT under the DC mode, which is a common operation on the traditional curve tracers. Traditional curve tracers have a pulse mode, but the function cannot work with knob sweep. On the other hand, the pulse mode on B1505A works even while using knob sweep.

25. Change the Power Compliance to OFF.



26. Change the Mode of the SMU3:HC (VAR1) from V to VPULSE.

27. Start the measurement again. (Click the REPEAT button .)

28. The graph is shown on the screen.

29. Self-heating effect becomes smaller than under the DC mode.

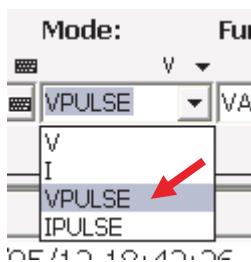

30. You can use the knob to change the stop voltage, etc. (Before changing voltage with the knob, you must click and select the stop voltage field.)

31. Click the STOP button  to stop the stimulus and measurement.

## Procedure **BVdss Measurement**

Next we will manually configure the setups for a breakdown measurement (BVdss), and then, measure the device. Setups for the SMUs are on the bottom of the graph window. Change these settings as follows.

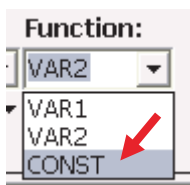
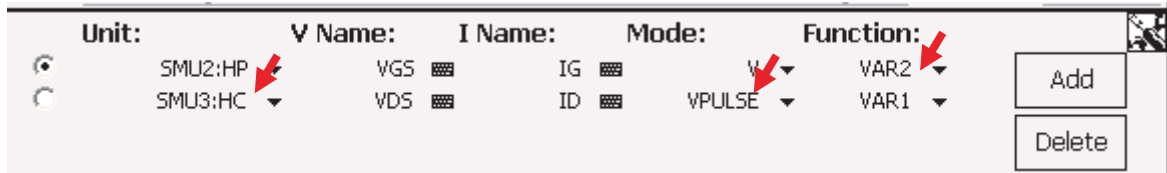

1. Change the Function of the SMU2:HP from VAR2 to CONST.
2. Change the lower selected unit (SMU3:HC) to SMU4:HV.

Now, we changed the measurement unit from the HC SMU to the HV SMU. But the connection is automatically changed by the module selector. So we do not need to change the connection manually.

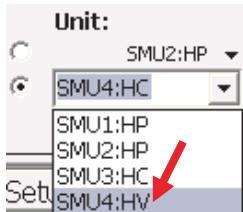

3. Change the Mode of the SMU4:HV from VPULSE to V.
4. Set the compliance of the VAR1 (VDS) to 1 mA.

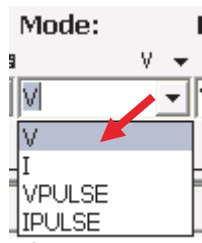



5. Change the display area. (Horizontal 0 to 3000 V, Vertical 0 to 1 mA). The present horizontal maximum voltage of the graph should be 200 V. Click the displayed voltage (200 V), and a window will pop-up. Next, input 3000. If the vertical maximum current is not 1 mA, change it in a similar manner.

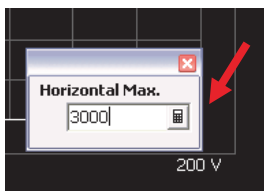

Next, we will setup the trace recorder. The trace recorder is a waveform recorder function similar to the segment memory of an infiniium oscilloscope. It is commonly used for recording and reviewing the state before the breakdown.



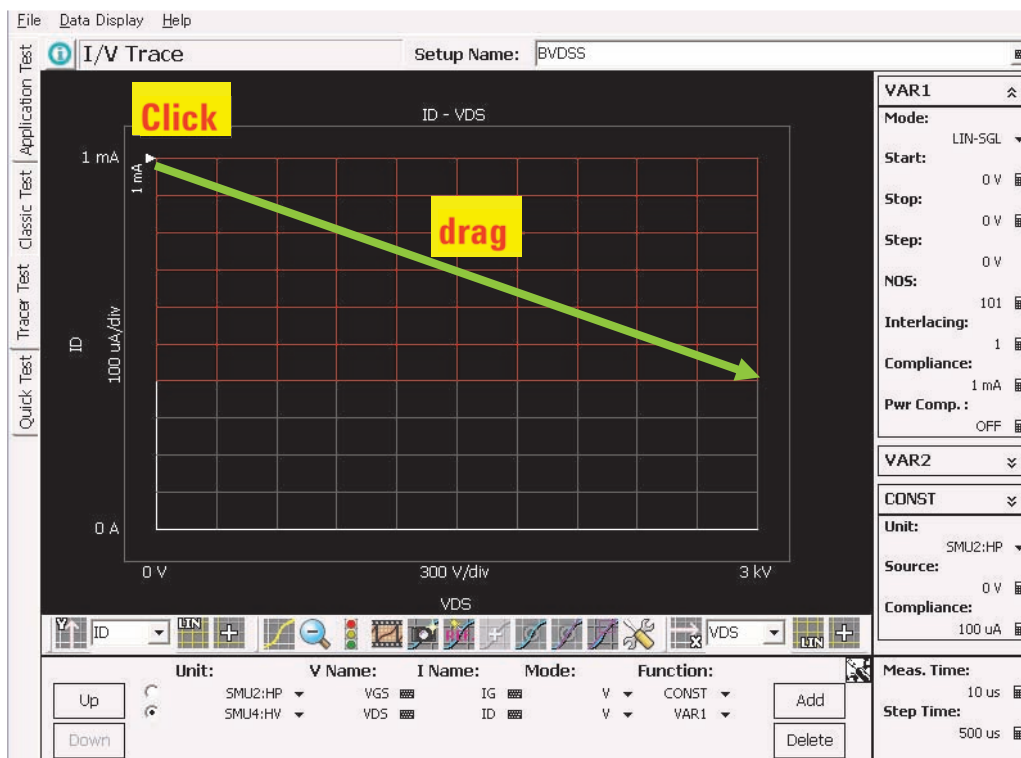

6. Set the stop region. While the stop region is effective, the measurement is automatically stopped if the measurement data is in the region. Click the signal button  , at the bottom of the graph. The button's signal changes to yellow  after clicking the button. (If the original signal color is not green, click the button a few times during the color change to yellow) You can now set the stop region.
7. Click and drag on the graph, The selected grids will turn red, indicating the stop area.
8. Confirm the settings are as shown below.
9. Click the REPEAT button  .



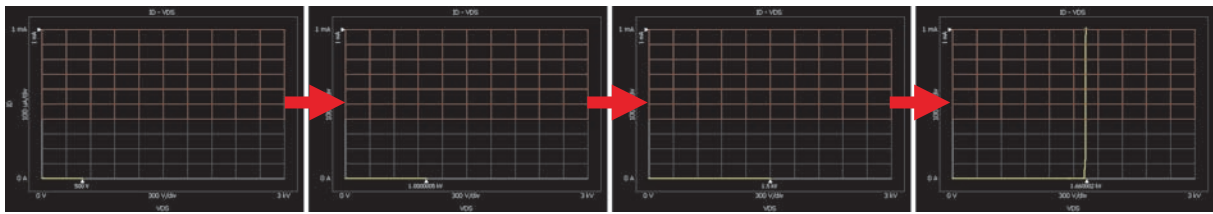
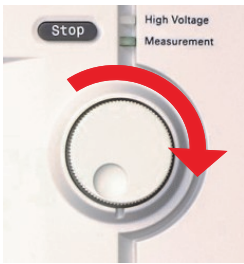

10. Click (Select) the VAR1 (Vd) Stop voltage .
11. Rotate the rotary knob on the front panel of the B1505A in the clockwise direction.
12. The stop voltage increases, and its graph is shown on the screen.
13. The DUT break down voltage is around 1600 V. The knob can be rotated at a fast speed up to 1400 V, but will slow down past 1400 V.
14. At around 1600 V, the breakdown will occur. At this time, the drain current will also becomes large enough to hit the stop region. After the trace hits the red area, the measurement stops automatically.
15. If you rotate the knob too fast, the Vds will be set larger than the break down voltage.



16. Review the measured data. Click the film icon  (record and replay button).
17. The following window will pops up. You can view the previous traces using the position indicator and the play back & forward buttons.

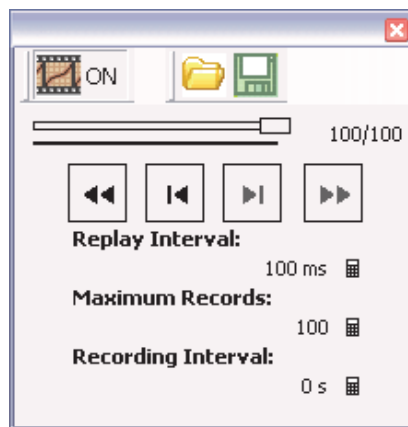



## Lab 2 Application Test Mode

- Easy setups for  $I_d$ - $V_{ds}$ ,  $I_d$ (off)- $V_{ds}$ ,  $I_d$ - $V_{gs}$  and  $C_{gd}$  measurements.

**Objective** EasyEXPERT has general device measurement settings as applications. Using that, you can measure the device without detail knowledge about the measurement. In this section, you can experience the easy-to-use concept of the EasyEXPERT.

- Point**
- Usability of the Application Test
  - Low current measurement capability of the HVSMU.
  - Automatic analysis
  - High Voltage C-V measurement.

**Device** MOS FET (2SK3745LS)

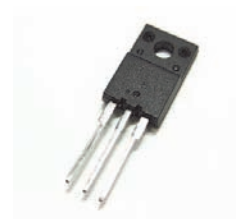

**Setup 1** This first procedure is exactly the same as for Lab1. If you are continuing from the Lab 1, you can skip this procedure.

Open the N1259A test fixture cover, and connect the test leads as follows. Refer to the drawing on the next page. The numbers on the drawing correspond to the procedure steps.

1. Insert the device (2SK3745LS) into the socket on the N1259A.
2. Connect the HPSMU2 Force to the terminal 1 on the 1 k $\Omega$  resistor.
3. Connect the terminal 2 on the 1 k $\Omega$  resistor to the terminal 1



*Test Lead for the N1259A Test Fixture*



Force (Gate) on the Inline Package Socket .

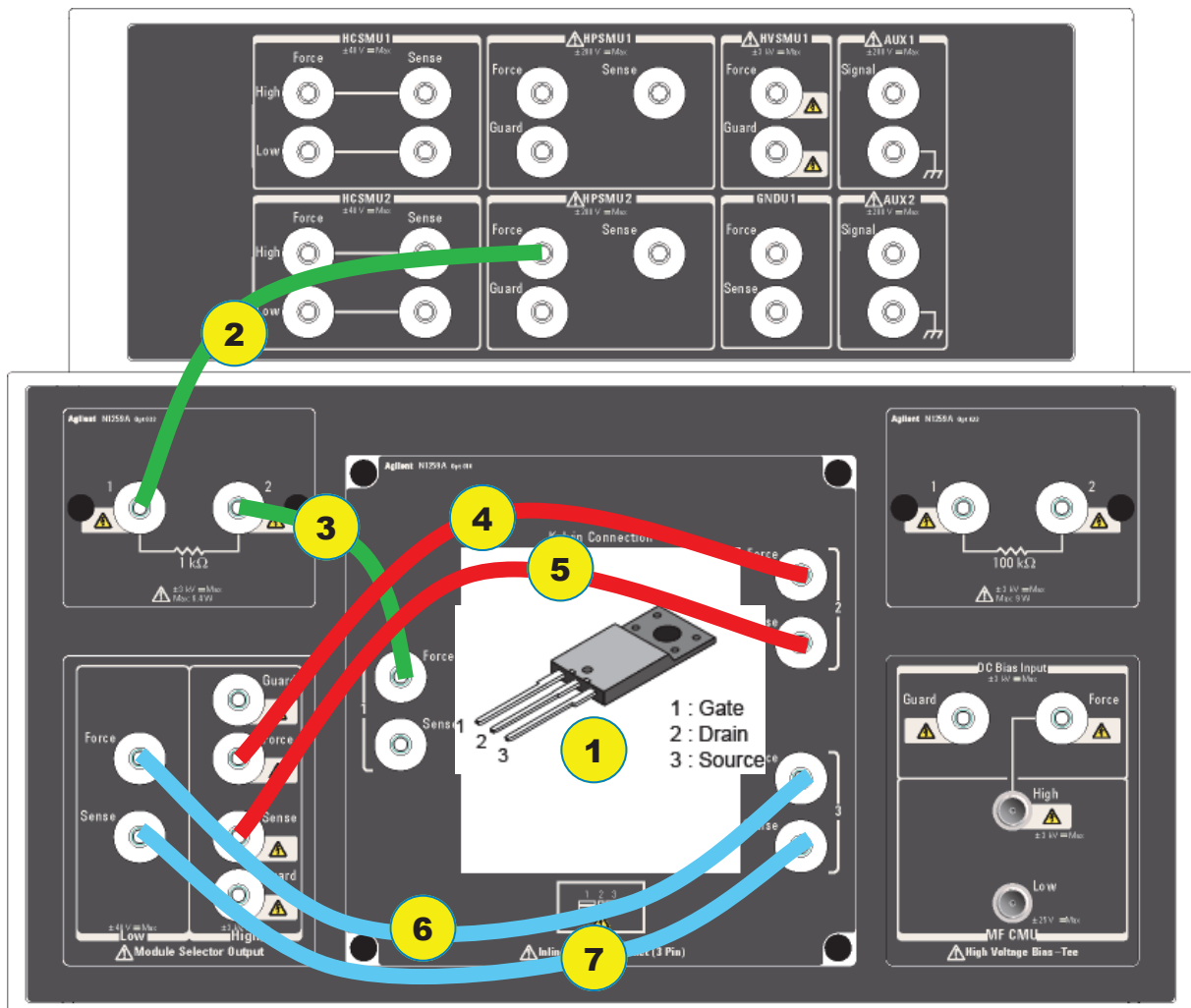

4. Connect the High Force of the Module Selector Output to the terminal 2 Force (Drain) on the Inline Package Socket .
5. Connect the High Sense of the Module Selector Output to the terminal 2 Sense (Drain) on the Inline Package Socket .
6. Connect the Low Force of the Module Selector Output to the terminal 3 Force (Source) on the Inline Package Socket .
7. Connect the Low Sense of the Module Selector Output to the terminal 3 Sense (Source) on the Inline Package Socket .

Close the N1259A fixture cover.

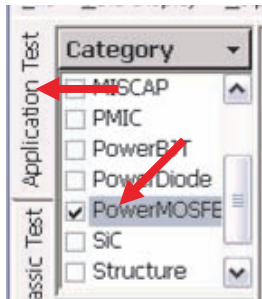

## Procedure Id - Vds Measurement





1. Click the Application Test tab.
2. Check the PowerMOSFET category.
3. Select Id-Vds (Click the Id-Vds then click Select )
4. Confirm that the test parameters as shown in the picture below.
5. Start the measurement. (Click the Single button )

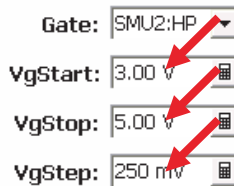

6. The graph window pops up and the measurement starts.
7. You can see the Id-Vd graph (See top left of next page).
8. Since the gate voltage settings are not so good, change the gate voltage settings (VgStart = 3 V, VgStop = 5 V, VgStep = 250 mV)

### Secondary Sweep



9. Measure again. (Click the Single button )
10. You can see more details on the graph (See top right of next page).

*EasyEXPERT has many default applications for basic measurements. You can measure the device easily, by simply selecting the desired application. With an illustrative user interface, you can intuitively modify the parameters to suit your DUT.*

*Next, we will perform another measurement, again by simply selecting an application.*

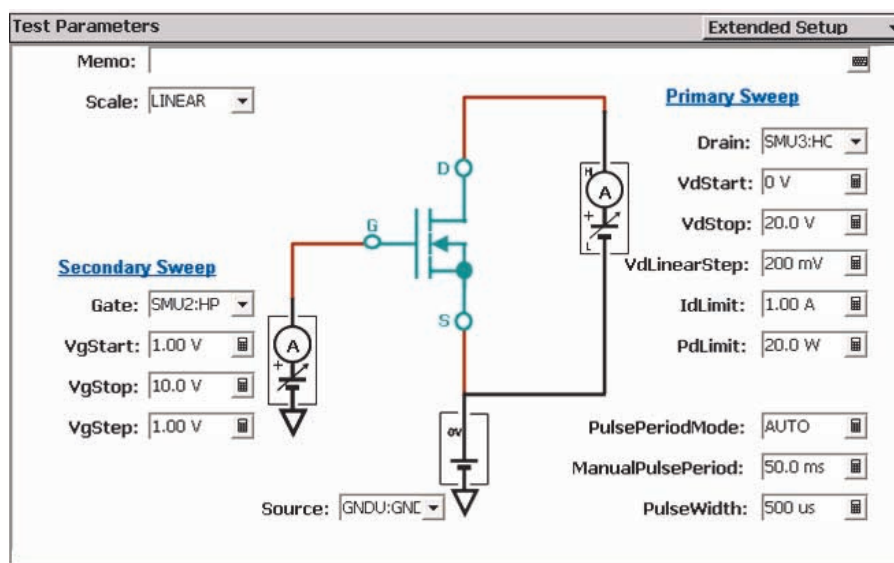

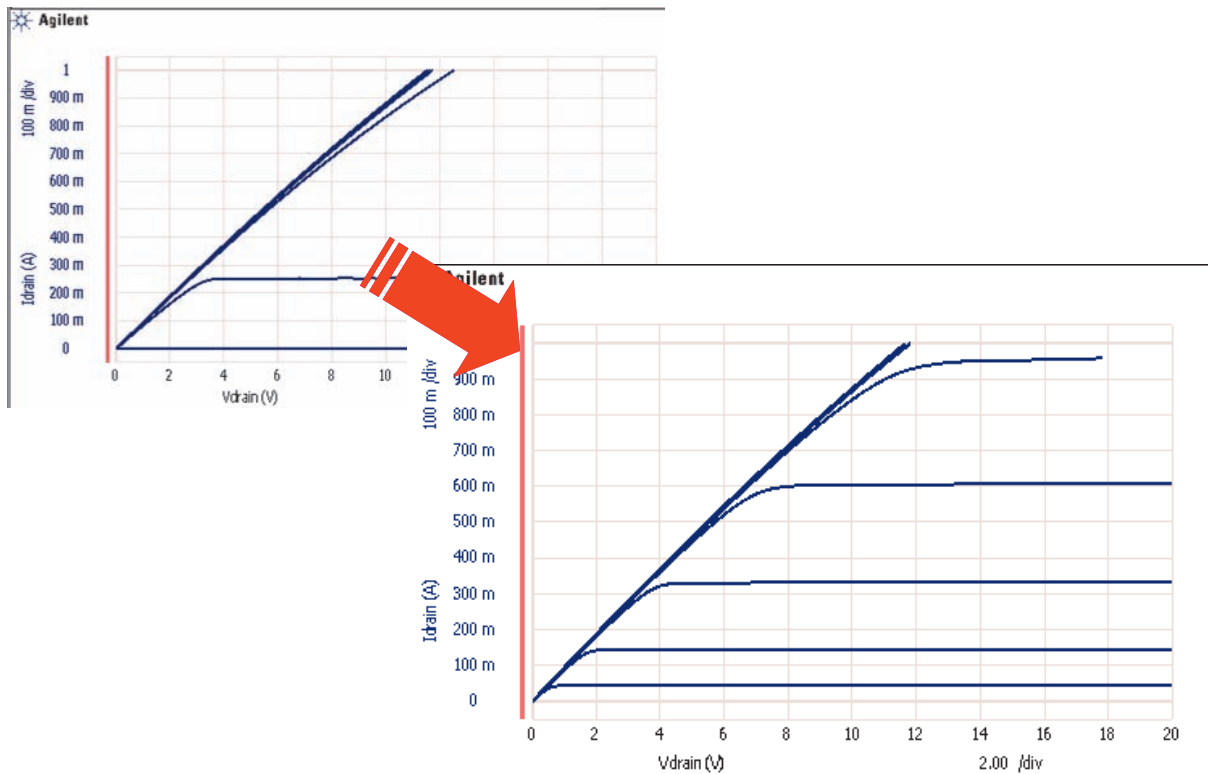

## Procedure Id(off) - Vds Measurement

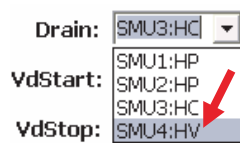
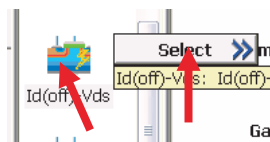

1. Select an application test of Id(off)-Vds.
2. Change Drain SMU to SMU4:HV
3. Change IntegTime to MEDIUM.
4. Open Extended Setup. (Click the Extended setup button ). The extended setup window will pop up.
5. Change IgMinRange and IdMinRange to 1 nA.
6. Close Extended Setup. (Click the Close button)

(The settings may be changed for the production version.)

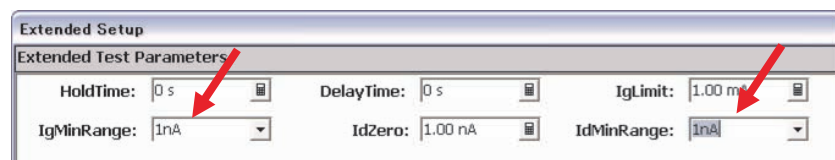



## Procedure Id - Vgs Measurement

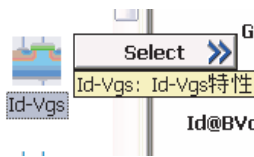

1. Select the application test of Id-Vgs.
2. Confirm that the settings are as shown in the picture below.
3. Start the measurement. (Click the Single button  .)
4. The graph window pops up and measurement starts.
5. After the measurement is completed, automatic analysis calculates the  $V_{th}$  and  $g_{fsMax}$ .

**Test Parameters** Extended Setup

Memo:

**Primary Sweep**

Gate: SMU2:HP

VgStart: 0 V

VgStop: 10.0 V

VgStep: 100 mV

**Secondary Sweep**

Drain: SMU3:HC

VdStart: 10.0 V

VdStop: 10.0 V

VdPoint: 1

IdLimit: 1.00 A

PulsePeriodMode: AUTO

ManualPulsePeriod: 50.0 ms

PulseWidth: 500 us

Source: GNDU:GNC

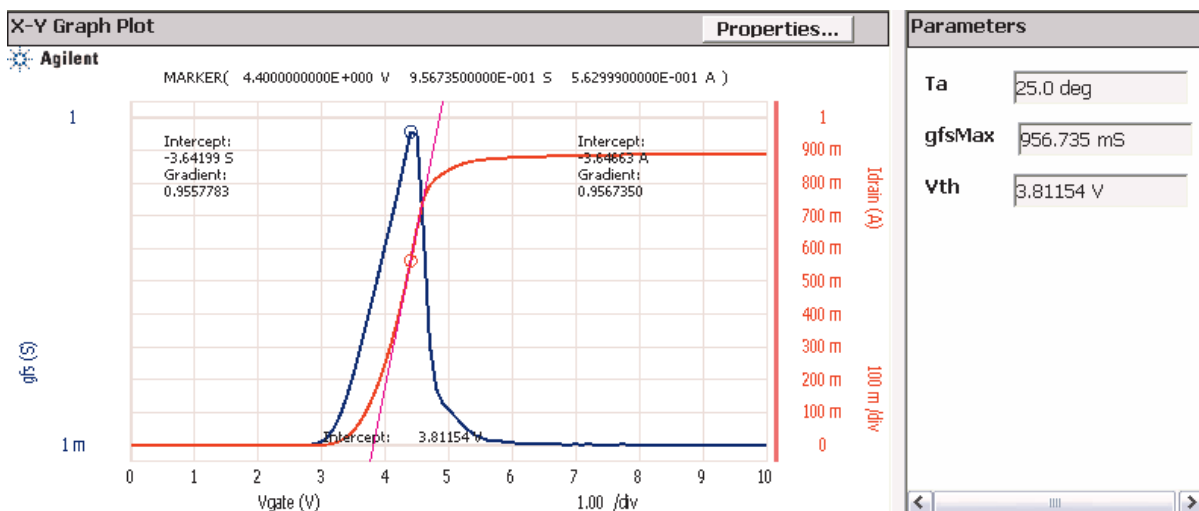

## Setup2

Open the N1259A test fixture cover, and connect the test leads and SHV cables as follows. Refer to the drawing on this page. The numbers on the drawing correspond to the procedure steps.

1. Insert the device (2SK3745LS) into the socket on the N1259A.
2. Using test lead, connect the AUX2 outer shield (GND) to the terminal 3 Force (Source) of the Inline Package Socket.
3. Using test lead, connect the High Force of the Module Selector Output to the DC Bias Input Force.
4. Using test lead, connect the High Sense of the Module Selector Output to the DC Bias Input Force.
5. Using test lead, connect the High Guard of the Module Selector Output to the DC Bias Input Guard.
6. Using a SHV cable and an adaptor, connect the MFCMU Low output to the terminal 1 Force (Gate) of the Inline Package Socket.
7. Using a SHV cable and an adaptor, connect the MFCMU High output to the terminal 2 Force (Drain) of the Inline Package Socket.

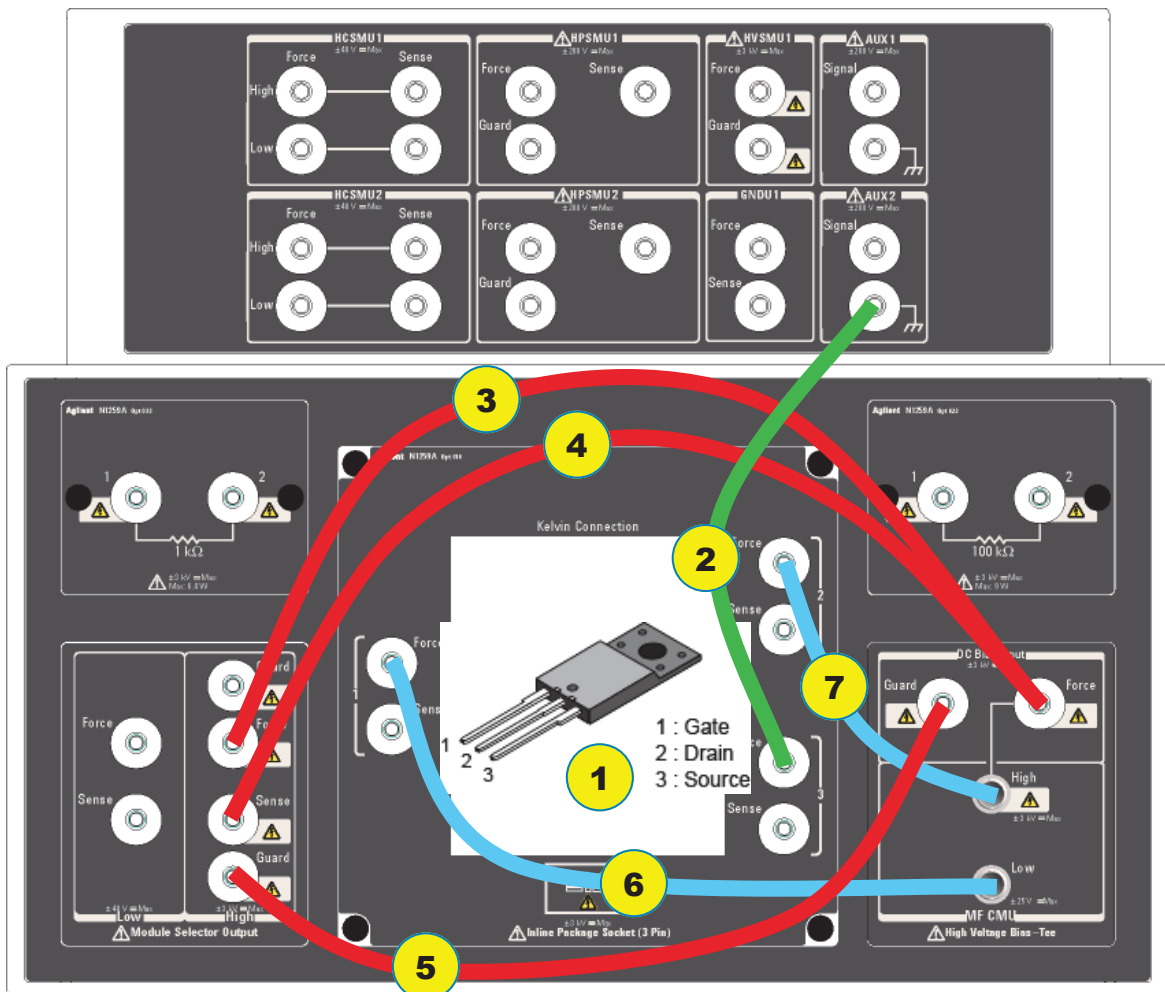



Close the N1259A fixture cover.





Test Lead for the N1259A Test Fixture

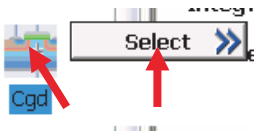

SHV cable and SHV-Banana Adaptor

## Procedure Cgd Measurement



1. Select the application test of the Cgd.
2. Confirm that the settings are as shown in the picture bellow.
3. Start the measurement. (Click the Single button  .)
4. The graph window pops up and the measurement starts.
5. If the vertical range of the graph is too large, change it by clicking the auto scale icon  .

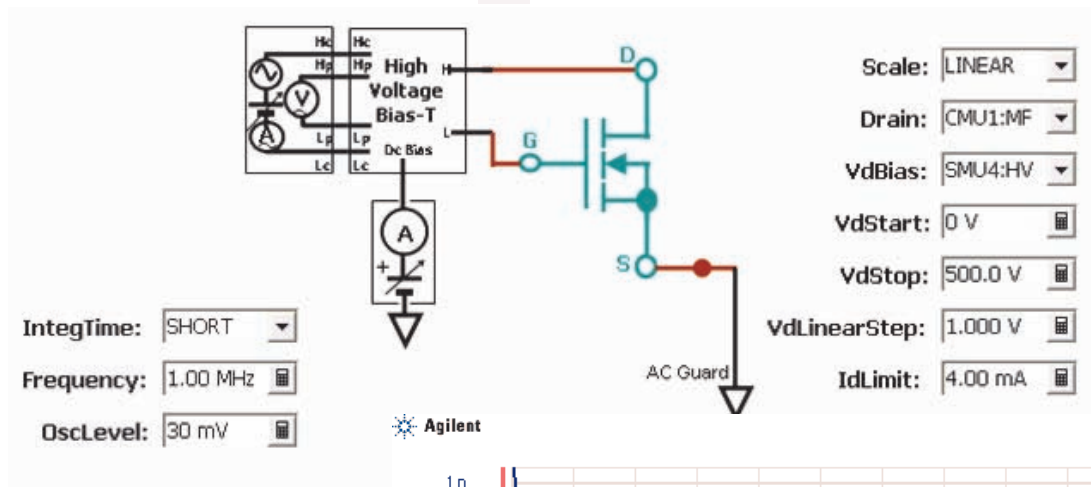

Agilent

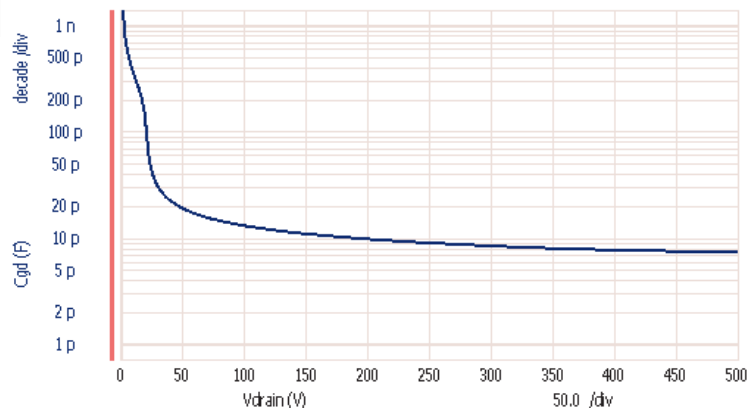



## Lab 3 Classic Test Mode 1

### - High Voltage C-V measurement.

**Objective** Easy Expert has a flexible test environment, Classic Test mode, which offers an interface similar to that of Agilent 4155/56. In this section, we measure the high-Voltage C-V, which is difficult to measure with the conventional system.

- Point**
- Usability of the Classic Test mode
  - High voltage C-V
  - Flexible measurement setup change

**Device** MOS FET (2SK3745LS)



**Setup** Open the N1259A test fixture cover, and connect the test leads and SHV cables as follows. Refer to the drawing on the next page. The numbers on the drawing correspond to the procedure steps.

1. Insert the device (2SK3745LS) into the socket of the N1259A.
2. Using a test lead, connect the terminal 1 Force (Gate) on the Inline Package Socket to the terminal 3 Sense (Source) on the Inline Package Socket .
3. Using a test lead, connect the High Force of the Module Selector



*Test Lead for the N1259A Test Fixture*



*SHV cable and SHV-Banana Adaptor*

Output to the DC Bias Input Force.

- Using a test lead, connect the High Force of the Module Selector Output to the DC Bias Input Force.
- Using a test lead, connect the High Guard of the Module Selector Output to the DC Bias Input Guard.
- Using a SHV cable and an adaptor, connect the MFCMU Low output to the terminal 3 Force (Source) on the Inline Package Socket.
- Using a SHV cable and an adaptor, connect the MFCMU High output to the terminal 2 Force (Drain) on the Inline Package Socket.

Close the N1259A fixture cover.

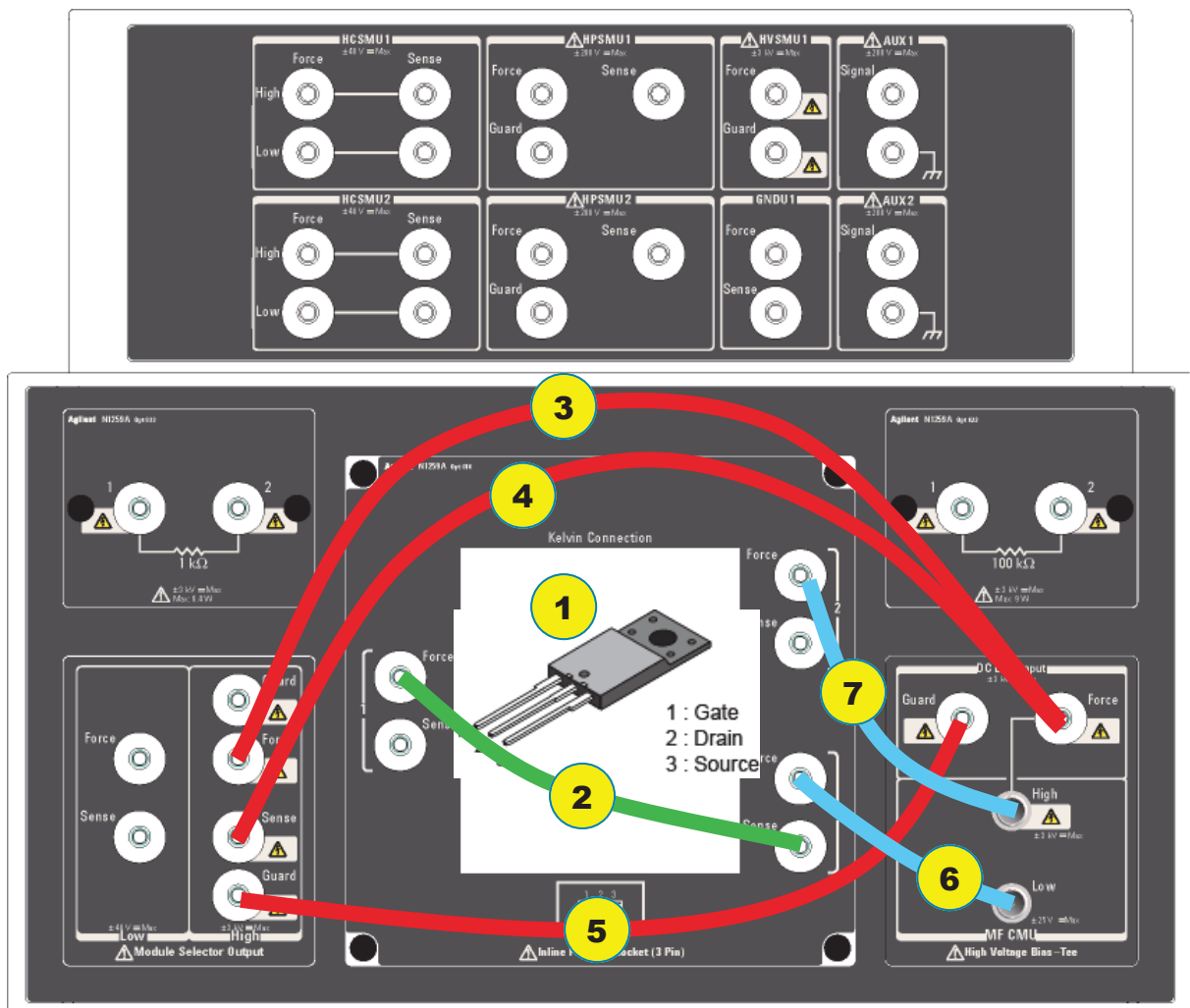

## Procedure Coss Measurement

1. Click the Classic Test tab.
2. Select the C-V Sweep.
3. Configure the Channel definitions as shown below, by selecting resources and clicking Delete button (or by using the Add SMU button).

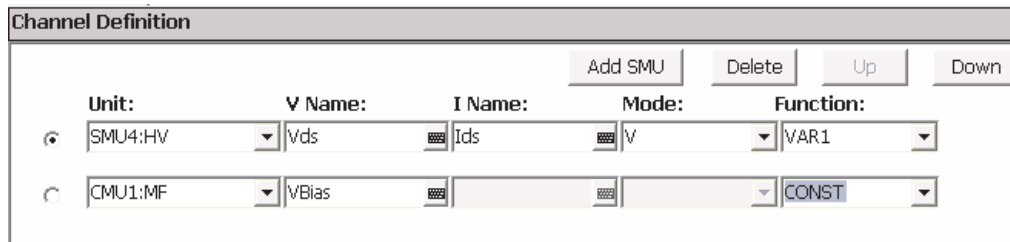
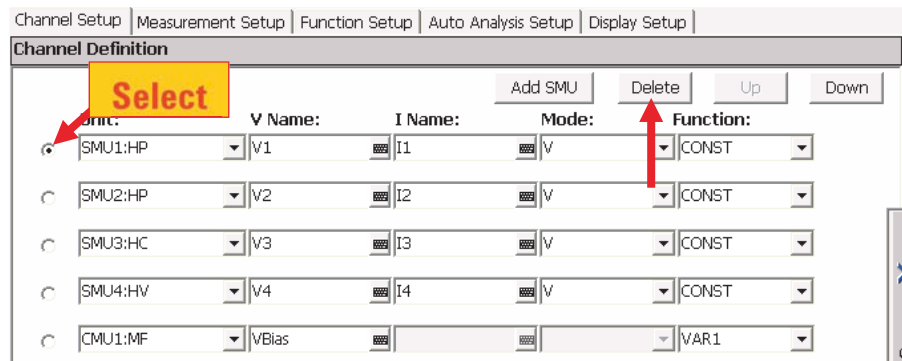
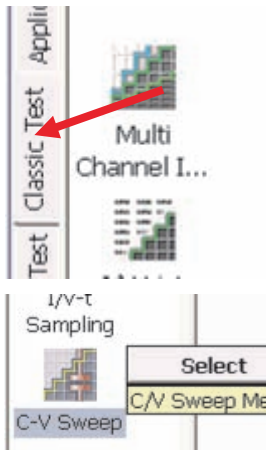

4. Select the Measurement Setup tab and change settings as shown below.

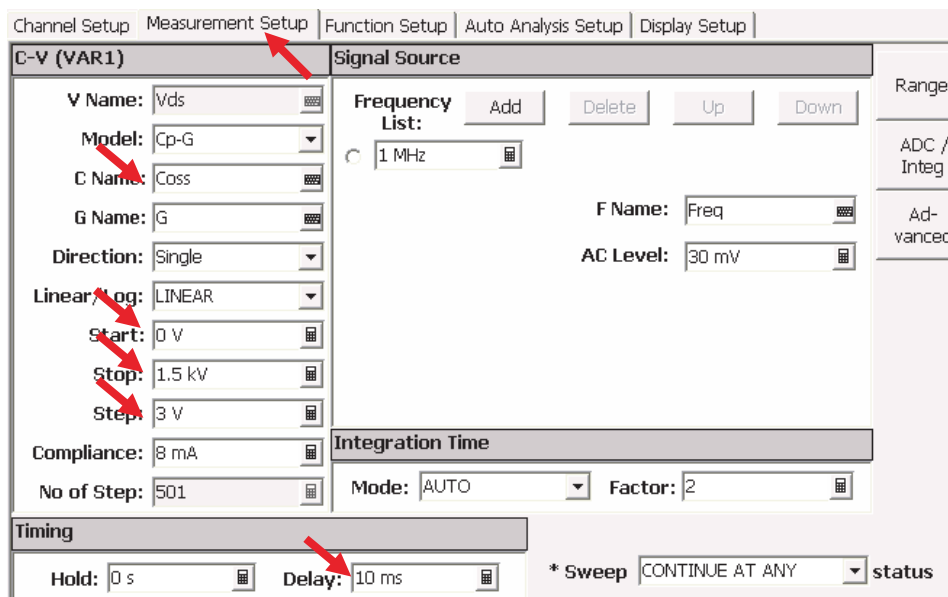

5. Select the Display Setup tab and change the settings as shown below.

The screenshot shows the 'Display Setup' tab for an X-Y Graph. The 'X' axis is configured with Name: Vds, Sharing: (None), Scale: Linear, Min: 0 V, and Max: 1.5 kV. The 'Y1' axis is configured with Name: Coss, Sharing: (None), Scale: Log, Min: 10 pF, and Max: 3 nF. The 'List Display' section shows 'Vds' and 'Coss' selected. The 'Parameters' section is empty.

6. Start the measurement. (Click the Single button  .)
7. The graph window pops up and the measurement starts.
8. The graph shows a stable high voltage C-V measurement up to 1500 V.

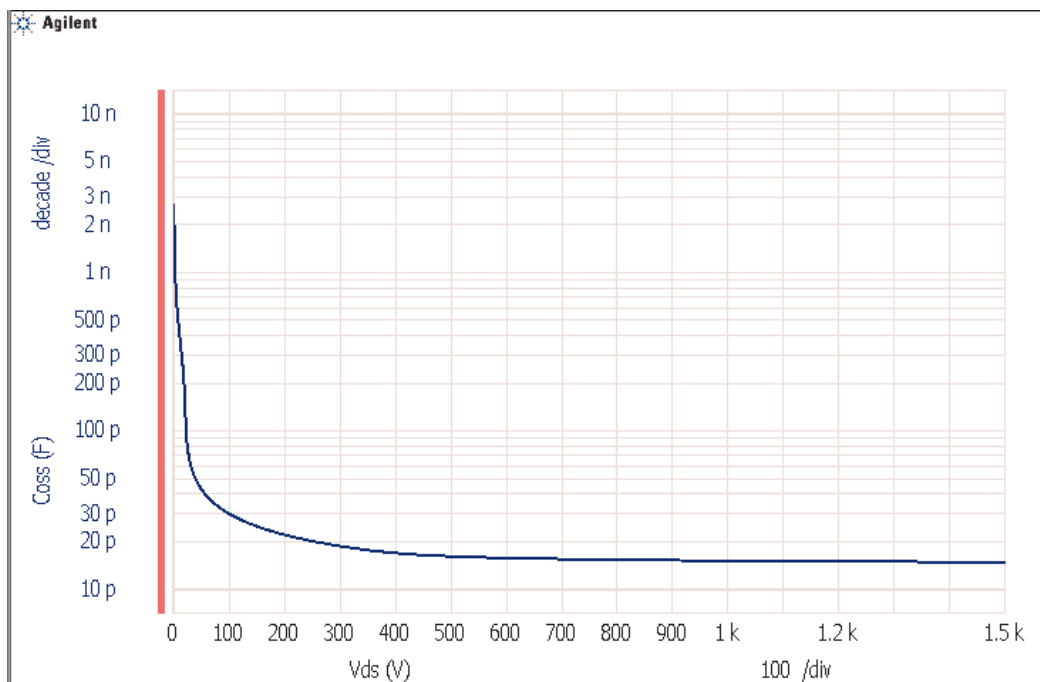

## Lab 4 Classic Test Mode 2

- Calculate  $R_e$  from  $I_b$ - $V_{ce}$  measurement results.

**Objective** In this section, we make a classic test mode setup for measuring the  $I_b$ - $V_{ce}$ , using the HCSMU. Auto analysis is then used to calculate the emitter resistance ( $R_e$ ).

**Point**

- Low voltage measurement performance of the HCSMU
- Measurement function
- Analysis Function

**Device** Power Bipolar Transistor (MJL4281AG)

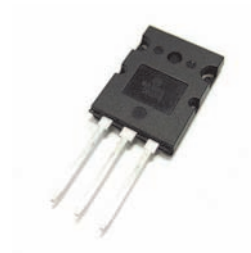

**Setup** Open the N1259A test fixture cover, and connect the test leads as follows. Refer to the drawing on the next page. The numbers on the drawing correspond to the procedure steps.

1. Insert the device (MJL4281AG) into the socket on the N1259A.
2. Connect the HPSMU2 Force to terminal 1 Force (Base) on the Inline Package Socket.
3. Connect the HPSMU2 Sense to terminal 1 Sense (Base) on the Inline Package Socket.
4. Connect the High Force of the Module Selector Output to the ter-



*Test Lead for the N1259A Test Fixture*

terminal 2 Force (Collector) on the Inline Package Socket.

5. Connect the High Sense of the Module Selector Output to the terminal 2 Sense (Collector) on the Inline Package Socket.
6. Connect the Low Force of the Module Selector Output to the terminal 3 Force (Emitter) on the Inline Package Socket.
7. Connect the Low Sense of the Module Selector Output to the terminal 3 Sense (Emitter) on the Inline Package Socket.

Close the N1259A fixture cover.

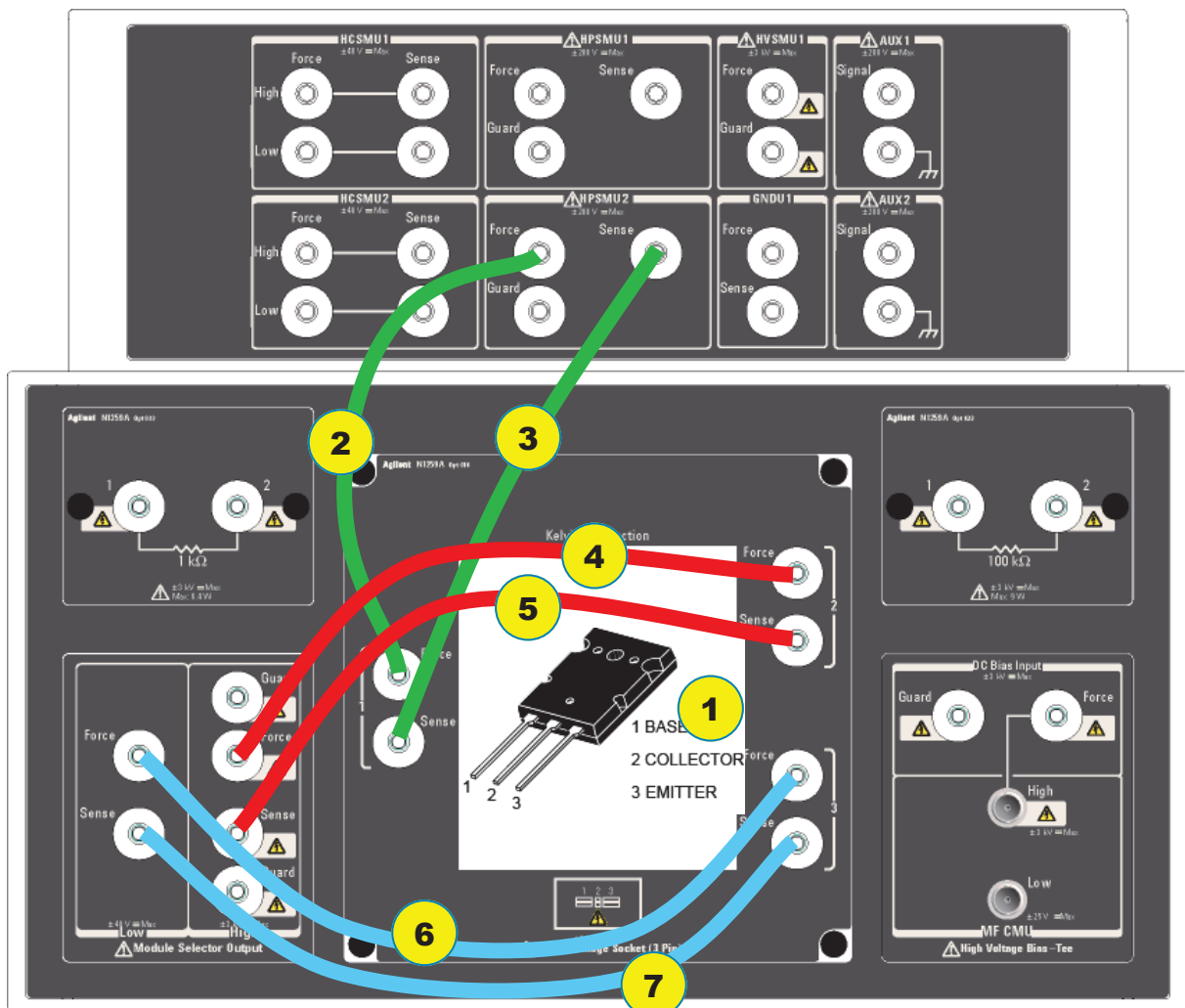

## Procedure Re Measurement



1. Click the Classic Test tab.
2. Select the I/V Sweep.
3. Configure the Channel Setup as shown below.

Unit	V Name	I Name	Mode	Function
SMU2:HP	Vb	Ib	I	VAR1
SMU3:HC	Vce	Ice	I	CONST

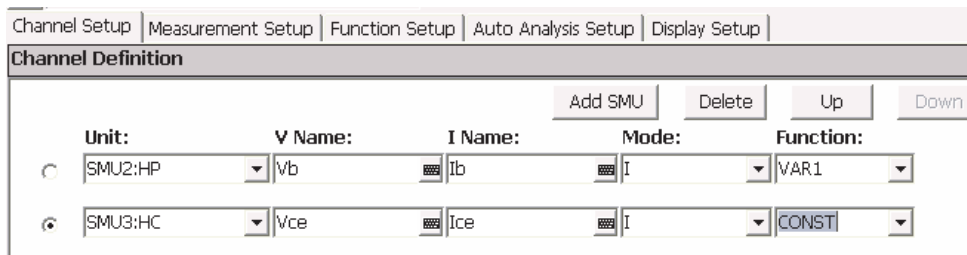

4. Configure the Measurement Setup as follows.

VAR1 (Ib sweep)

Start 1 mA, Stop 100 mA, Step 1 mA

Constants

SMU3:HC Source:1  $\mu$ A, Compliance: 2 V

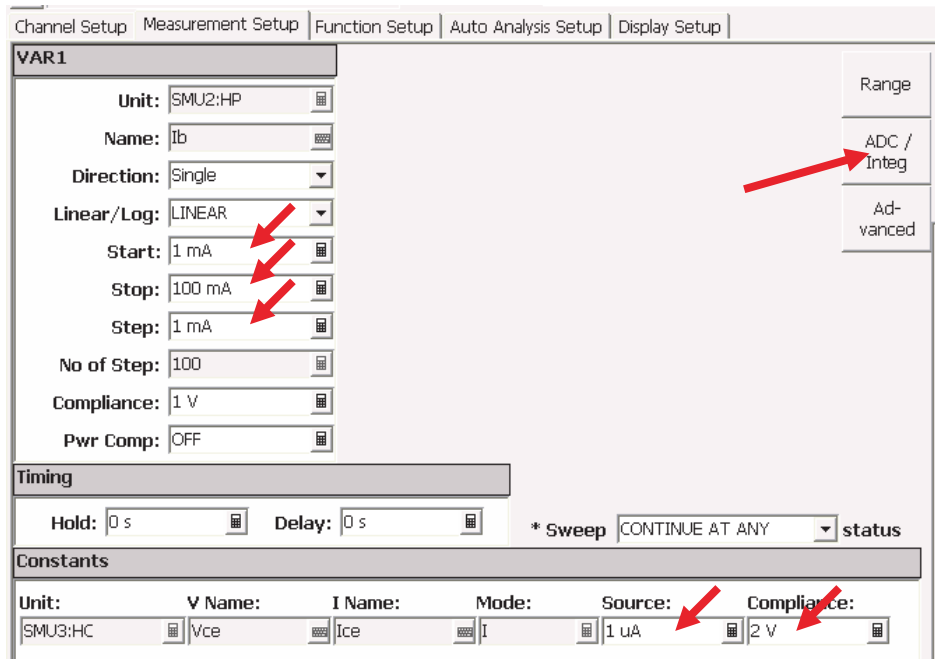



- Click the ADC/Integ button on the Measurement setup. Then configure the A/D converter as follows.

SMU3:HC HSADC

Hi Speed ADC Mode = PLC, Factor = 1

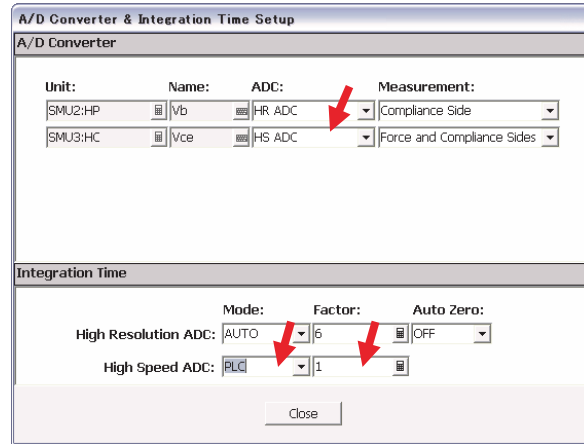

- Next, Configure the Display setup as follows.

	Name	Sharing	Scale	Min	Max
X:	Vce		Linear	0 V	10 mV
Y1:	Ib	(None)	Linear	0 A	100 mA

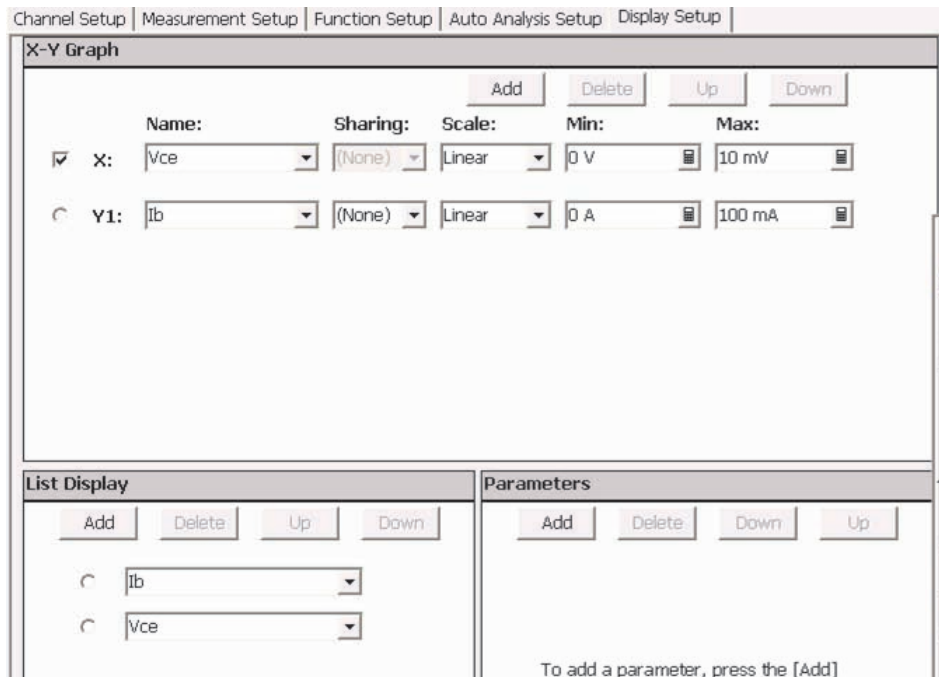

7. Start the measurement. (Click the Single button  )
8. The graph window pops up, and the  $I_b$  -  $V_{ce}$  trace is shown in the low  $V_{ce}$  region.

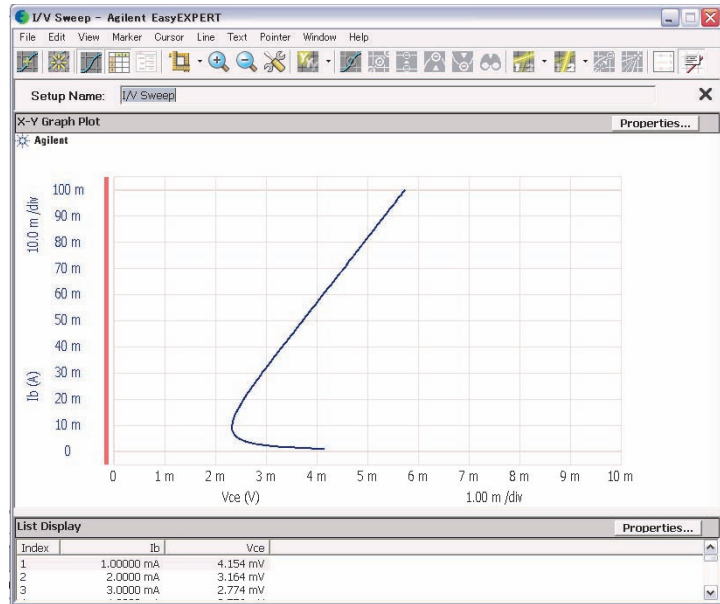

Next we will use Auto analysis to calculate the  $R_e$  (ohm). The  $R_e$  is calculated from the gradient of the  $I_b$ -  $V_{ce}$  curve. In this case, the curve of the  $I_b$  from 40 mA to 100 mA is almost straight, so use the data of that area and make a regression line,

9. Click the Auto Analysis Setup tab.
10. Check Enable for Line 1.
11. Select the type of the Regression.
12. Select the Data Condition for the First Point and the Second Point.
13. Set the conditions as shown below.

Condition	
First Point	$I_b = 0.04$
Second Point	$I_b = 0.1$

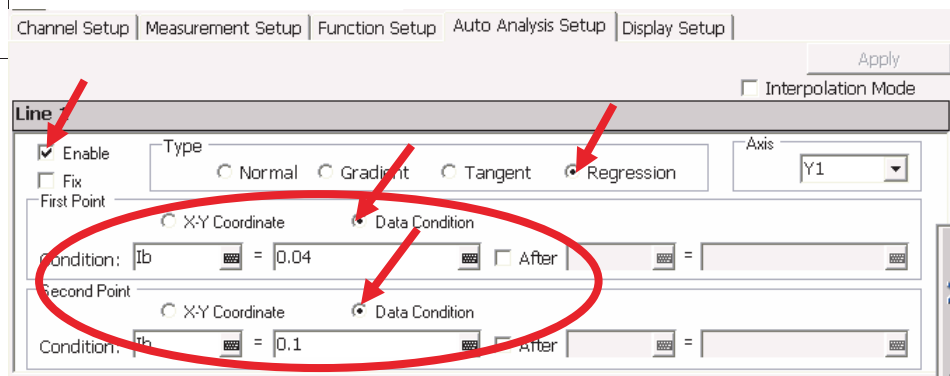



14. Select the Function Setup tab.
15. Write an **Analysis Function** (NOT a User Function) as follows.

Name	Unit	Definition
Re	ohm	1/@L1G

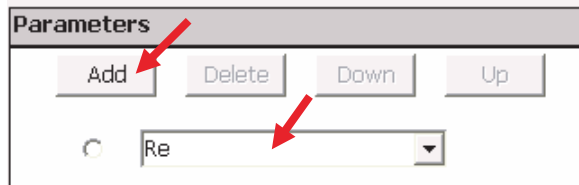

16. Click the Display Setup tab, and add a Parameter of Re.



17. Start the measurement. (Click the Single button  .)
18. The graph window pops up. After finishing the measurement, two cursors and a regression line are automatically drawn. Then the Parameter of Re is calculated.

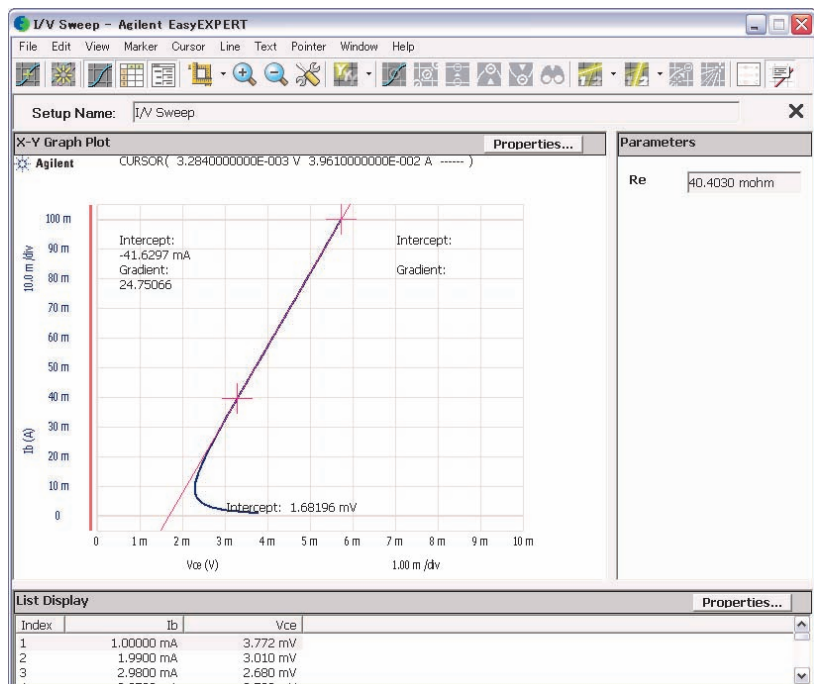

## Lab 5 Convert the Tracer Test Mode setups to the Classic Test Mode setups

- Seamless setup conversion.

**Objective** Tracer test mode is an easy, intuitive, and interactive environment for device measurement, and is useful to tuning the measurement conditions. B1505A has the function of convert the Tracer test settings to the Classic test settings. In this section, we use the Tracer test mode to decide the test condition, and use the Classic test mode for a more detailed measurement and analysis.

- Point**
- Seamless conversion from the Tracer test mode to the Classic test mode
  - Store setups to the My Favorite
  - High Current measurement capability of the HCSMU

**Device** Power Bipolar Transistor (MJL4281AG)

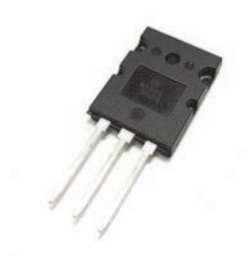

**Setup** The connection of the DUT is exactly the same as for Lab 4. If you are continuing from Lab 4, you can skip the procedure.

Open the N1259A test fixture cover, and connect the test leads as follows. Refer to the drawing on the next page. The numbers on the drawing correspond to the procedure steps.

1. Insert the device (MJL4281AG) into the socket on the N1259A.
2. Connect the HPSMU2 Force to terminal 1 Force (Base) on the



*Test Lead for the N1259A Test Fixture*

Inline Package Socket.

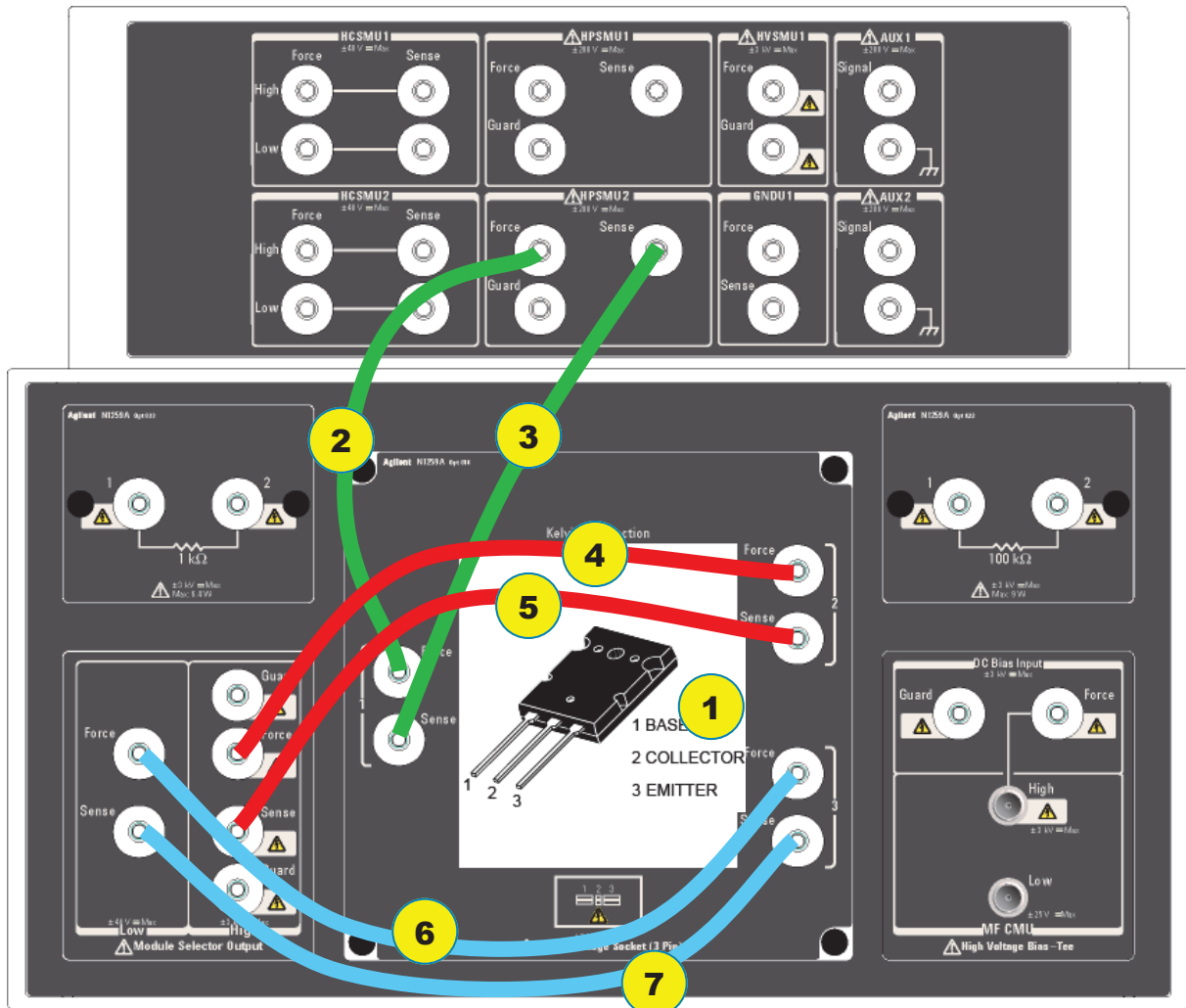

3. Connect the HPSMU2 Sense to terminal 1 Sense (Base) on the Inline Package Socket.
4. Connect the High Force of the Module Selector Output to the terminal 2 Force (Collector) on the Inline Package Socket.
5. Connect the High Sense of the Module Selector Output to the terminal 2 Sense (Collector) on the Inline Package Socket.
6. Connect the Low Force of the Module Selector Output to the terminal 3 Force (Emitter) on the Inline Package Socket.
7. Connect the Low Sense of the Module Selector Output to the terminal 3 Sense (Emitter) on the Inline Package Socket.

Close the N1259A fixture cover.

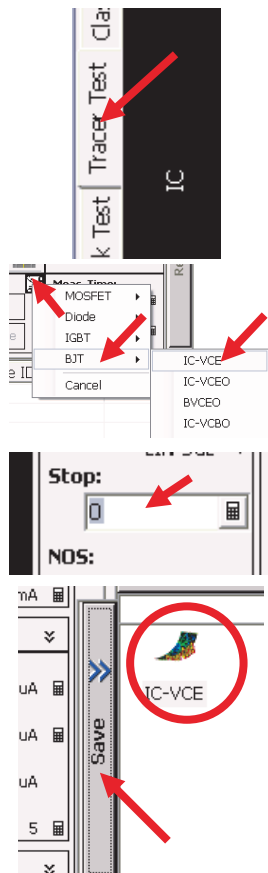

## Procedure Save and Recall



1. Click the Tracer Test tab.
2. Click the Sample setup icon and select the BJT - IC-VCE.
3. Click on the VAR1, VAR2, and CONST title bar to open the detail settings (Full mode). Click on the setting window. The mouse cursor changes to a hand icon. You can scroll by dragging the mouse.
4. Change setting as shown in the bottom picture.
5. Start the measurement. (Click the Repeat button .)
6. Select Stop voltage of the VAR1 and change it to 20 V using the knob or the keyboard.
7. Finish the measurement. (Click the STOP button .)
8. Click the Save to My favorite button. You will see a new icon appear in the My Favorite Setup.

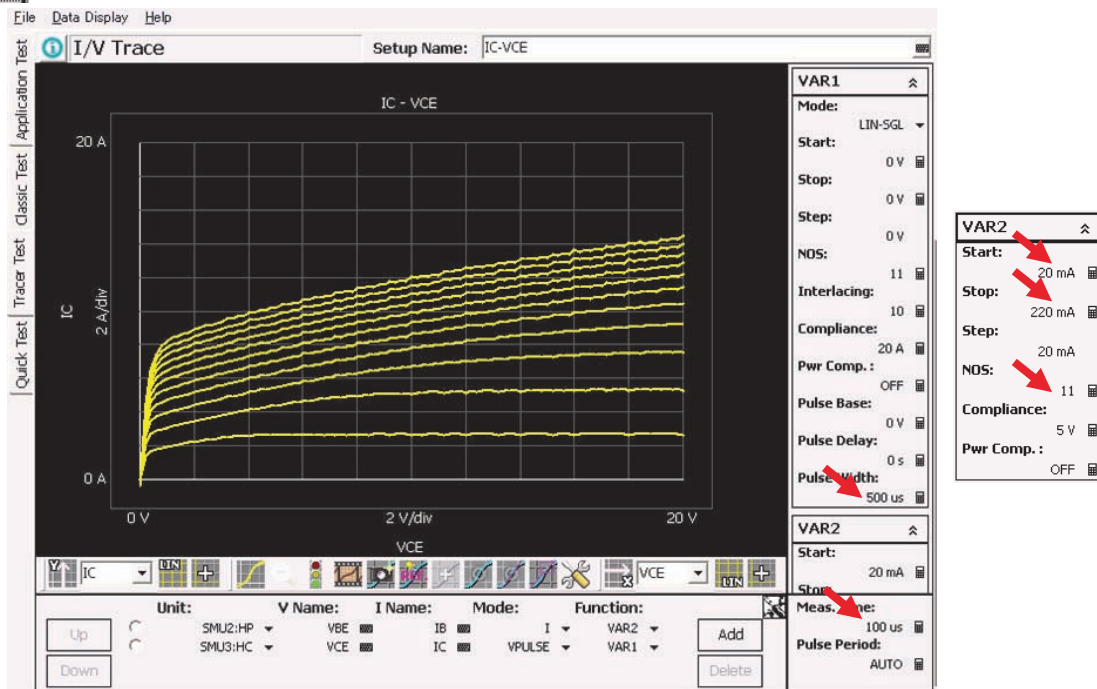
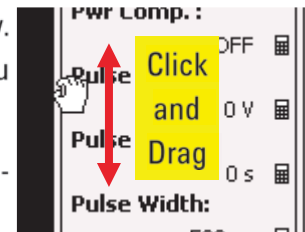



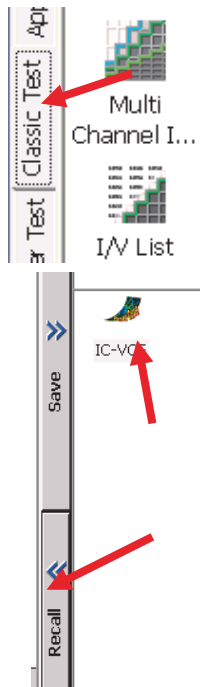

We have now saved the Tracer Test mode setup as IC-VCE. You can recall it under the Tracer Test mode, as well as under the Classic Test mode. Next we will do that.

(Note that you cannot recall Classic Test setups under the Tracer Test mode).

9. Click the Classic Test tab.
10. Select the saved setup (IC-VCE) and click the Recall My favorite button.
11. You will see the setup recalled as a classic test of a Multi Channel I/V Sweep.
12. Start the measurement. (Click the Single button  )
13. The graph window pops up and the measurement starts.

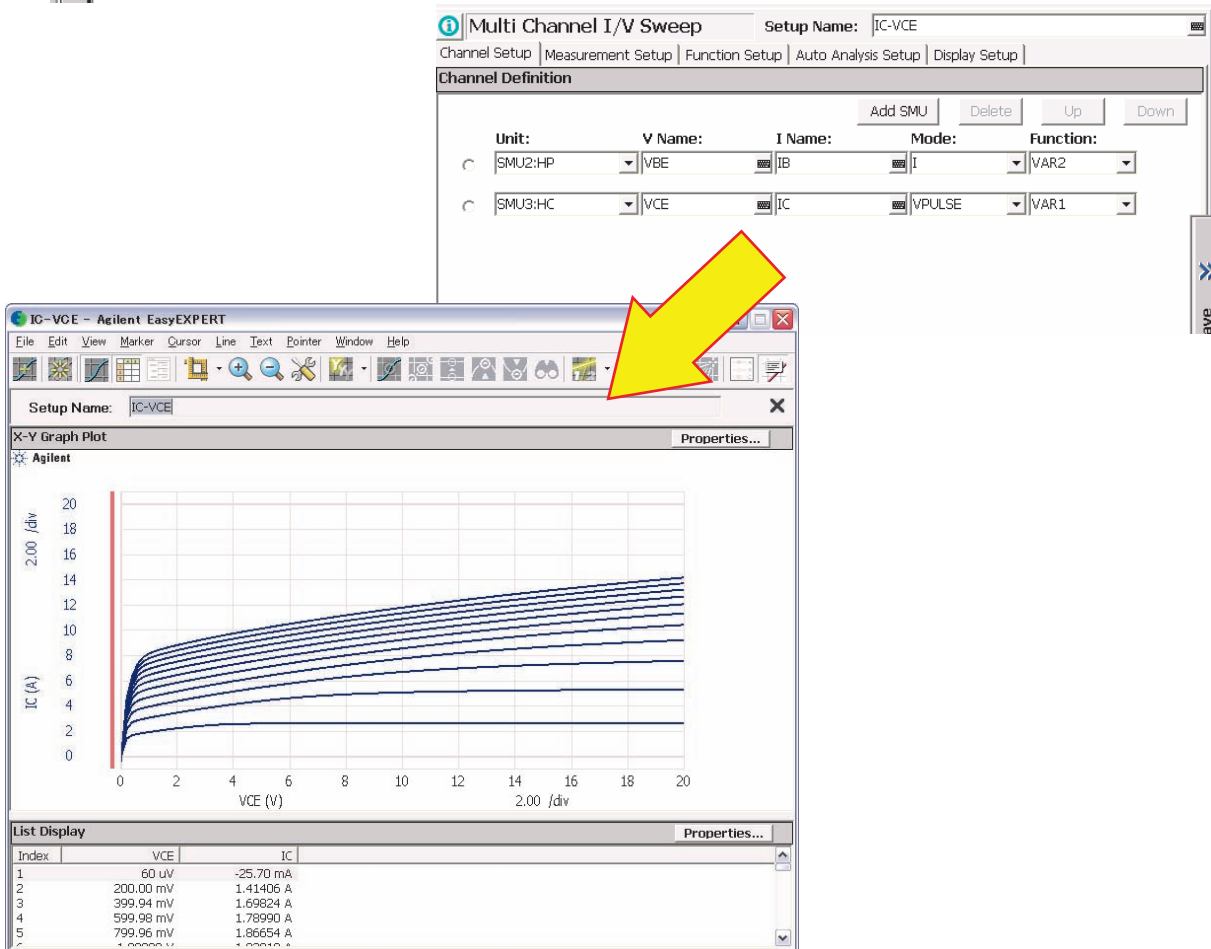

## Lab 6

# Data analyze on your PC with the Desktop EasyEXPERT

- Easy data transfer and analyze

### Objective

Desktop EasyEXPERT is a software for PCs. It offers almost the same environment as EasyEXPERT on B1505A. Using Desktop EasyEXPERT, you can control B1505A from your PC. And more, you can check and analyze data, collected with B1505A.

B1505A uses the Windows OS environment. And has high affinity with other windows software such as Microsoft Excel.

### Point

- Desktop EasyEXPERT usability
- Compatibility
- Export data for other software

### Procedure

#### B1505A to Desktop EasyEXPERT and Excel.

1. Insert a USB memory into the B1505A.
2. Select the measurement data you want to export.
3. Right click and select Transport Data - Export As Test Result. (This is for Desktop EasyEXPERT.)
4. Save the file onto the USB memory. (Specify the directory and file name as you desire)
5. Repeat steps 2 though 4 to export the data in CSV format (this time, selecting Export As CSV... instead of Export As Test Result)

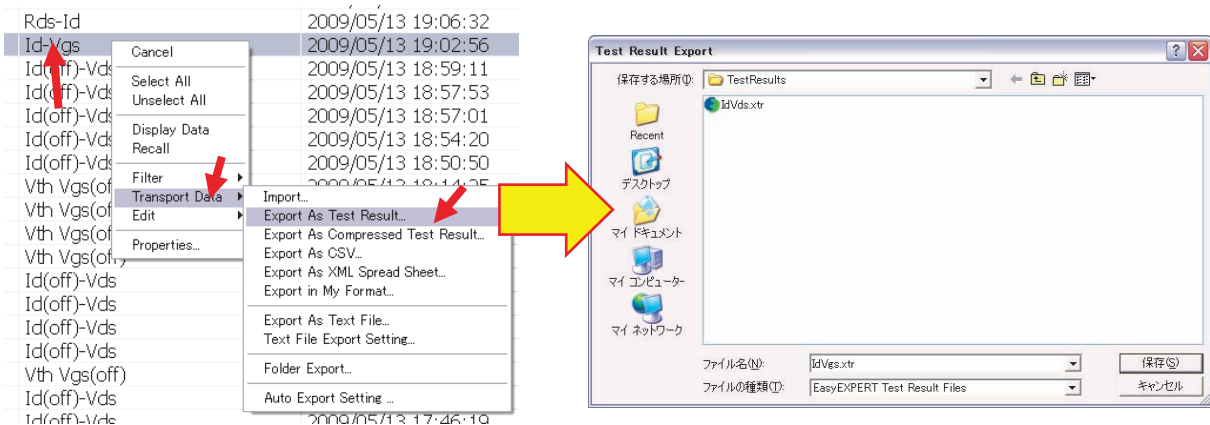

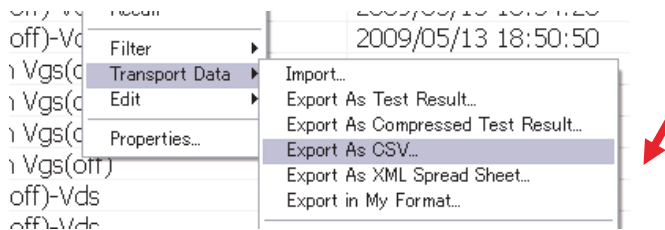

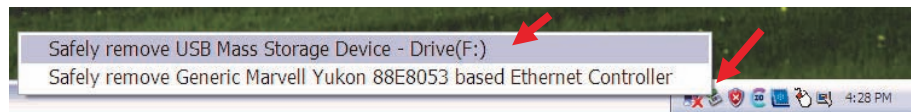

- Remove the USB memory from B1505A. (**Important: Before removing the USB memory, Please follow the safely remove procedure of the Windows OS.**)

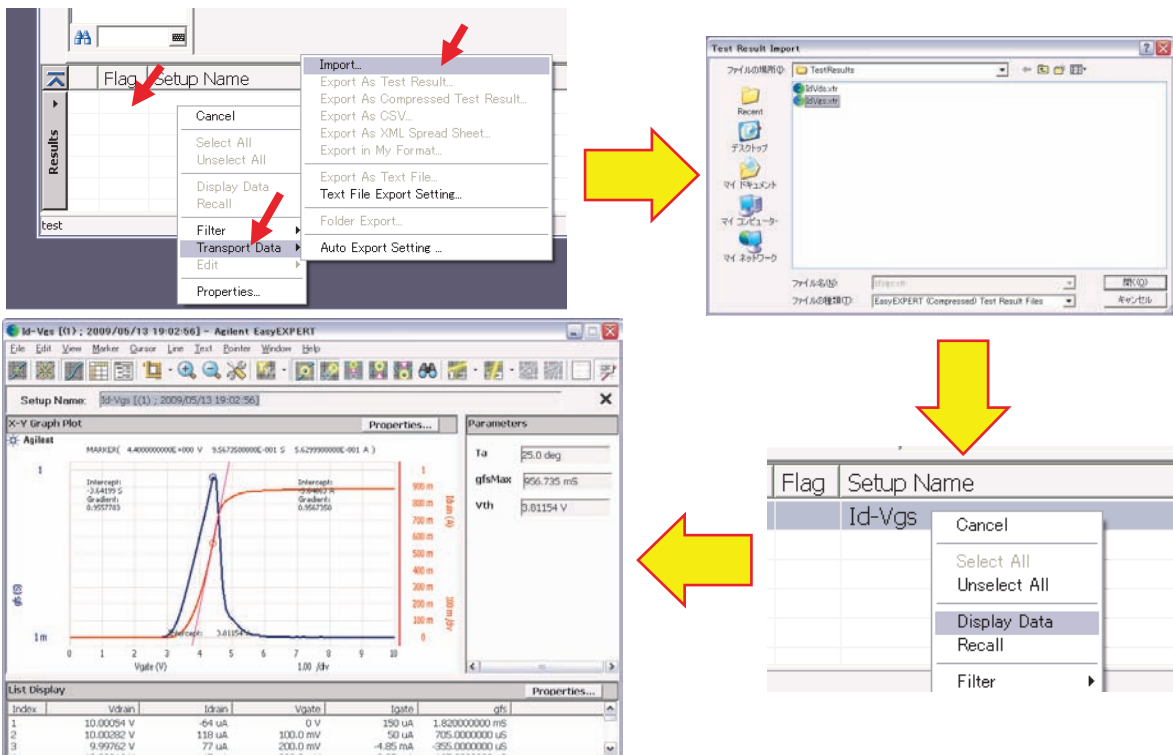

- Turn on your PC and start Desktop EasyExpert.
- Insert a USB memory into your PC.
- Right click on a Results field.
- Select Transport Data - Import.
- Right click the transported data and select Display Data.
- The graph window pops up.



13. Start an Excel on your PC.
14. Load the saved CSV file.
15. Select the area for which you want to see a graph.
16. Click the graph button  to plot the graph. (Select the graph type, change graph properties, etc.)

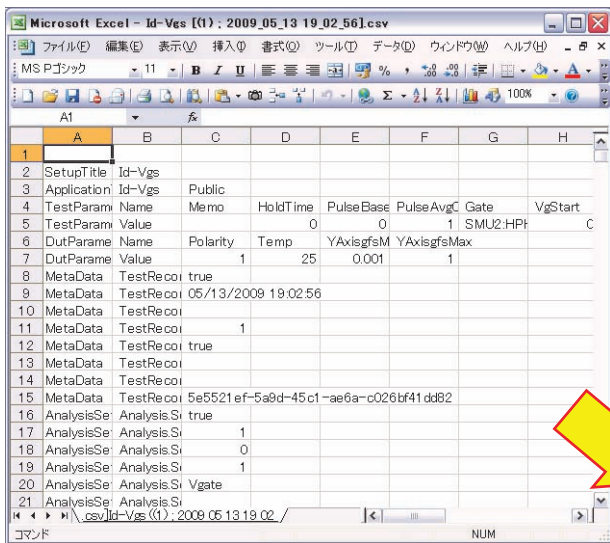

AnalysisSei	AnalysisSi	Vgate	Igate	Idrain	Vdrain	Ta	gfs
0	0.00015	-6.40E-05	10.00054	25	0.00182		
0.1	5.00E-05	0.000118	10.00282	25	0.000705		
0.2	-0.00485	7.70E-05	9.99762	25	-0.00036		
0.3	-0.00985	4.70E-05	10.00316	25	0.000165		
0.4	-0.0148	0.00011	9.99532	25	0.00021		
0.5	-0.01975	8.90E-05	10.00596	25	-0.00026		
0.6	-0.02475	5.90E-05	9.99992	25	-0.00059		
0.7	-0.0297	-2.90E-05	9.99656	25	0.00015		
0.8	-0.0347	8.90E-05	9.9997	25	0.00021		
0.9	-0.03975	1.30E-05	9.99978	25	-0.00034		
1	-0.04465	2.10E-05	9.99652	25	-5.00E-06		
1.1	-0.0496	1.20E-05	9.99864	25	1.00E-05		
1.2	-0.05455	2.30E-05	9.99902	25	-5.00E-05		
1.3	-0.05955	2.00E-06	10.00458	25	0.000145		
1.4	-0.06455	5.20E-05	9.99732	25	0.000105		
1.5	-0.0695	2.30E-05	10.00136	25	-0.00061		
1.6	-0.0745	-6.90E-05	9.99792	25	-0.00015		
1.7	-0.0795	-8.00E-06	10.0009	25	0.00082		
1.8	-0.08445	9.50E-05	10.00256	25	6.00E-05		
1.9	-0.0894	4.00E-06	10.00166	25	-1.50E-05		

